

Wireless Radio Control of Puppets

Hardware Setup Overview

Setup Overview

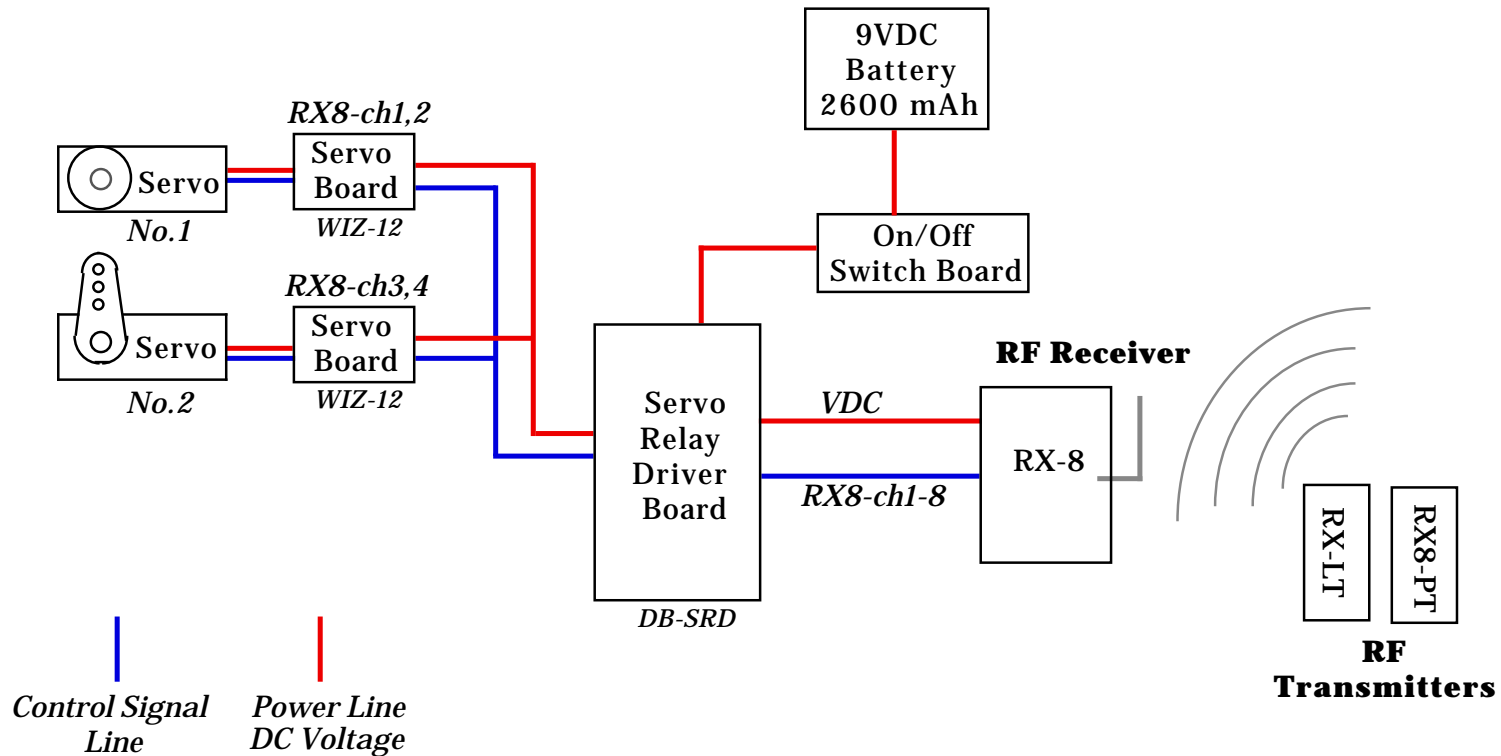

Copyright © 2011 Blue Point Engineering All Rights Reserved

For more information on these products or to place an order

Blue Point Engineering Inc.

www.BPEsolutions.com

Phone (303) 651-3794

COMPONENTS / PARTS

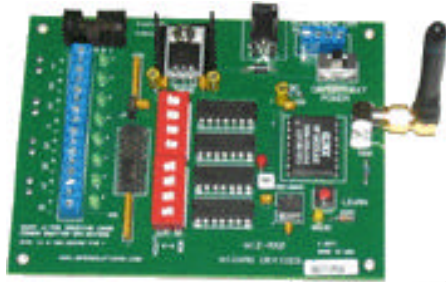

**RX-8
RF Receiver
Board**



**Servo Driver
Board (Wiz12)**



Servos



**RF Short Range
Key fob
Transmitter**



**RF Long Range
Transmitter**



**Ribbon Cable
with Connectors**

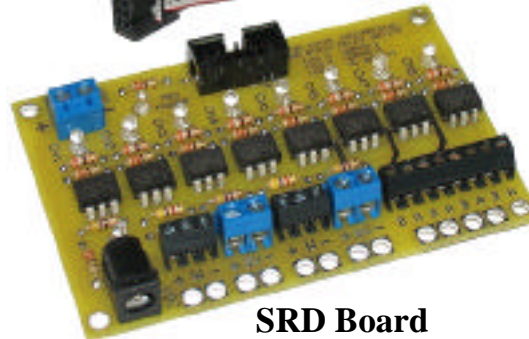

SRD Board



**Power / On Off -
Distribution Board**



**Battery
9VDC @ 2.4 Amps**



**Servo Driver
Board (Wiz12)
Power Connecto**

**2.1 x 5mm Power
Jack (Male)
Center Positive**



**Battery
Power Connector**

**2.1 x 5mm
Power Jack
(Female)
Center
Positive**



**Hook-up
Wire**

3 Wire (Black - Red - White)

RX8 to SRD Board

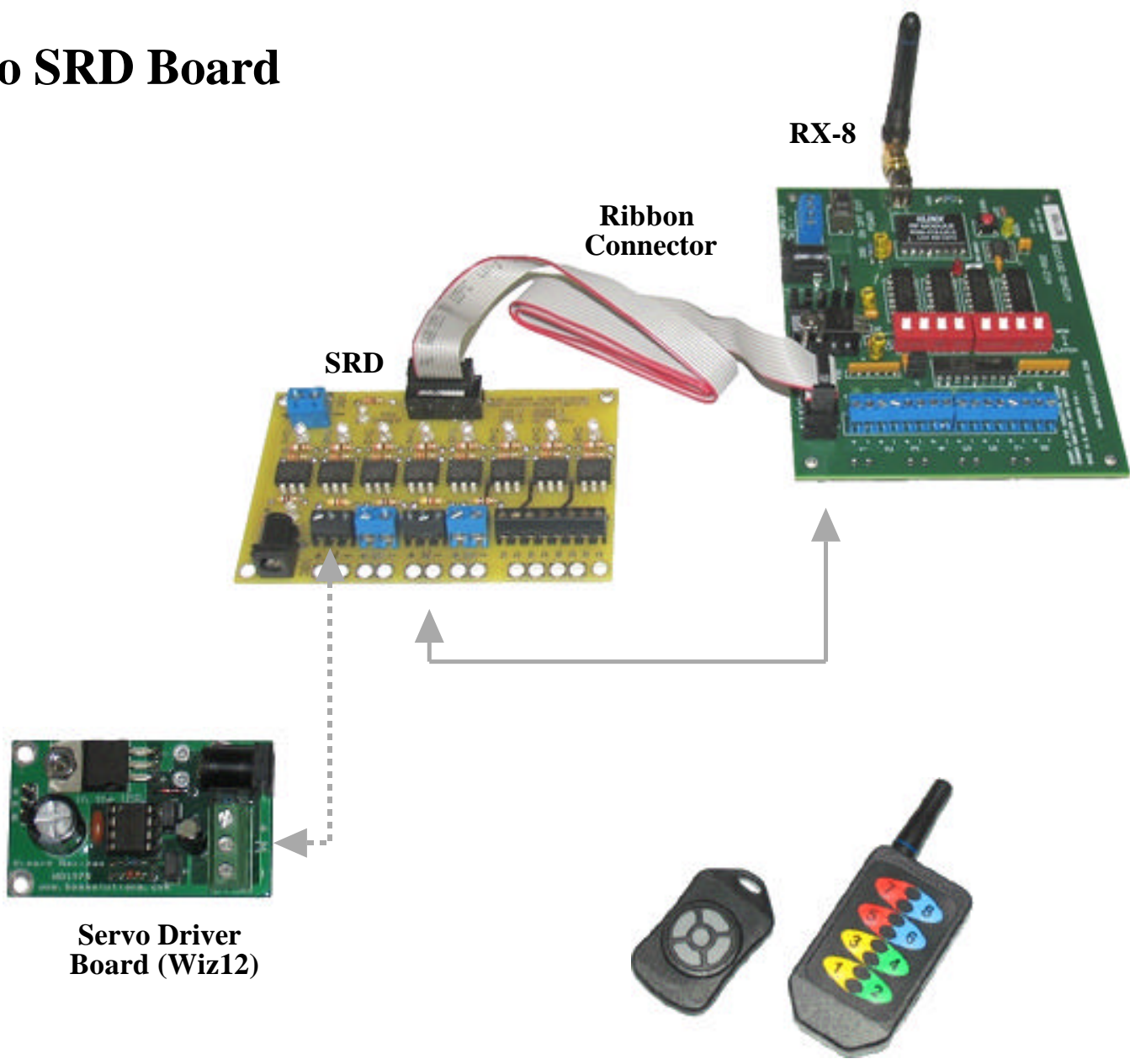

Control Wire Setup R/C Servo Setup

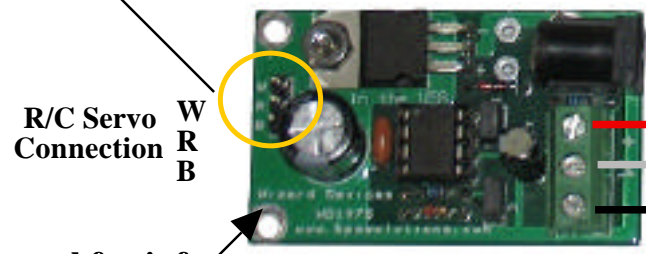
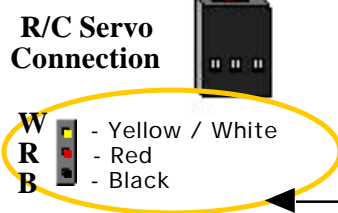
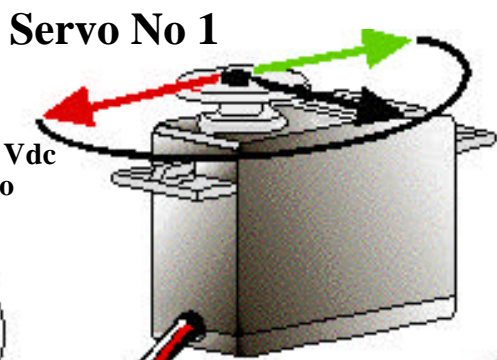
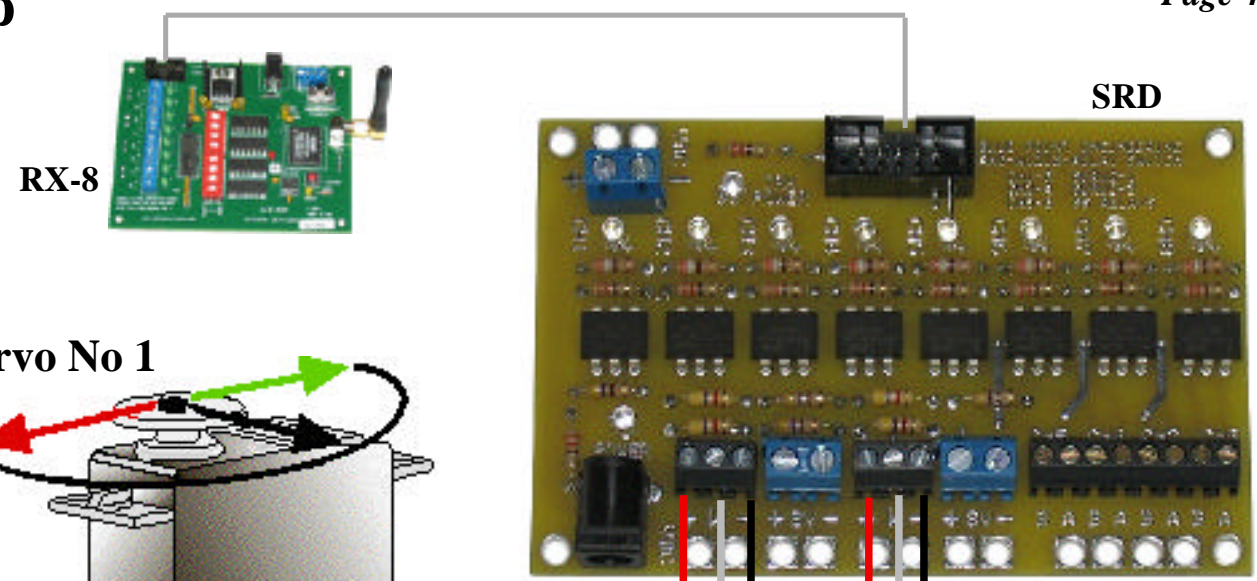

See Operation Manual for info
on programming Wizard-12
Board Servo Travel Limits

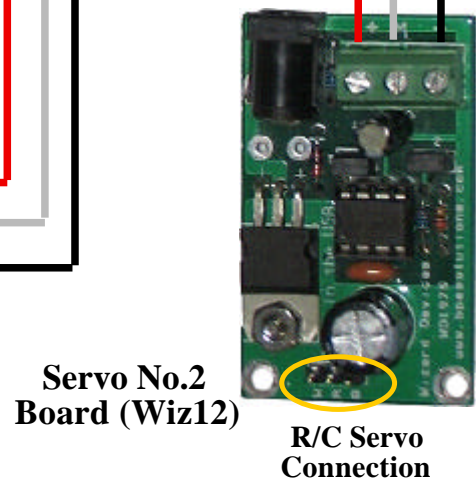
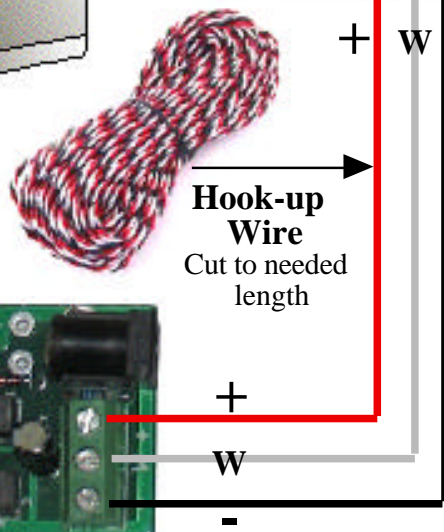

Power Setup

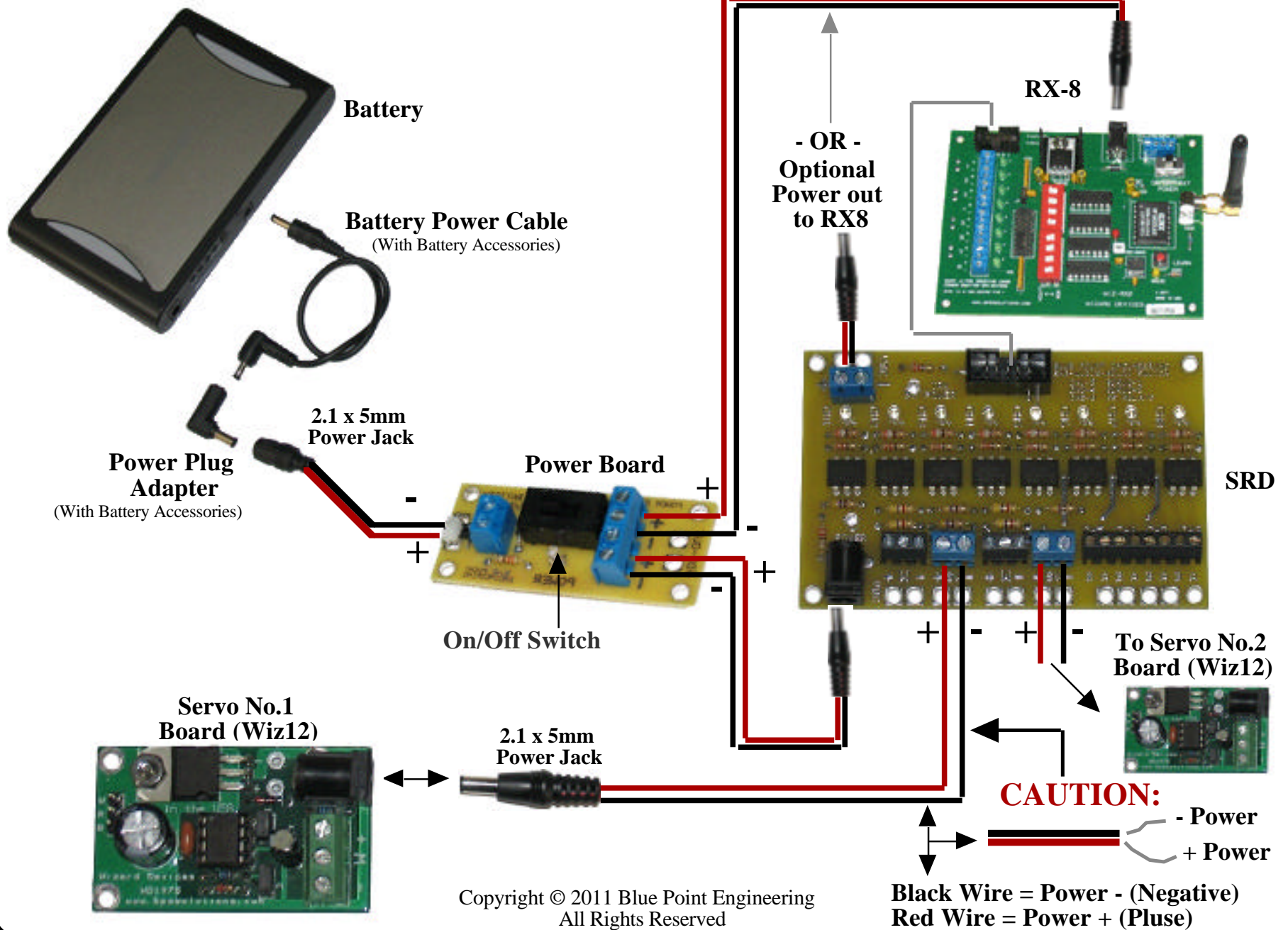

SRD Board Overview

Servo / Relay Driver Board

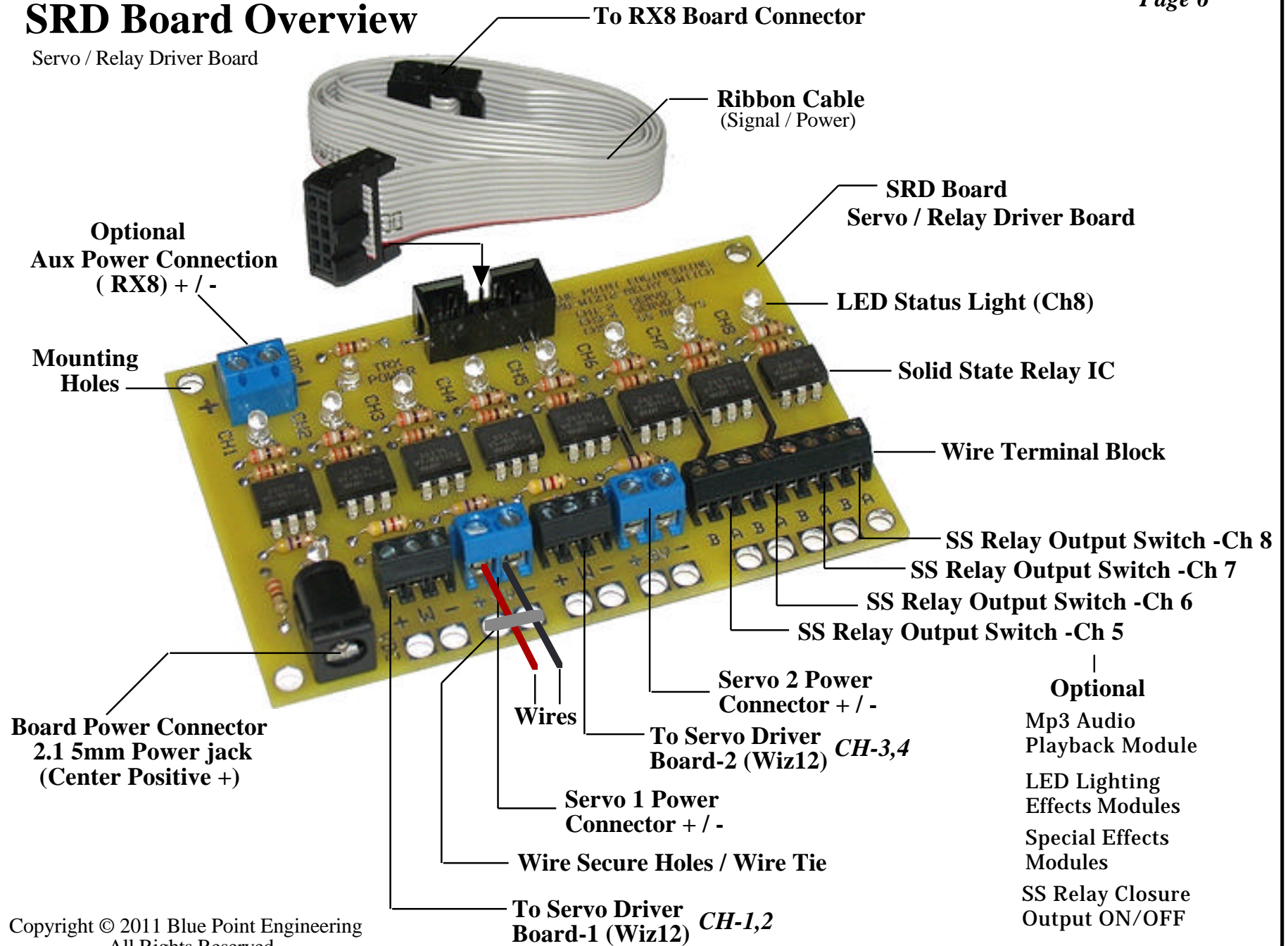

RX-2 Overview

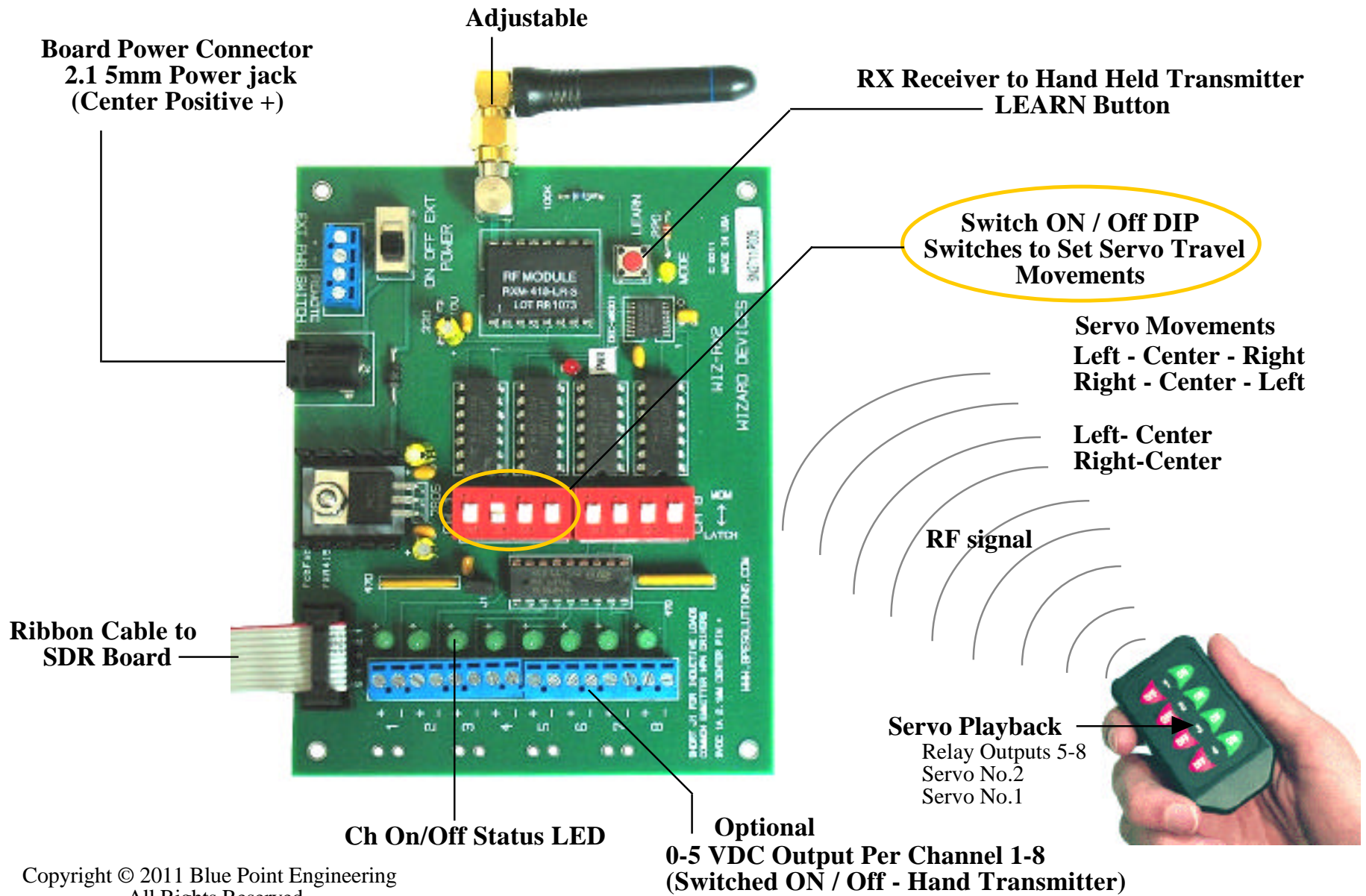

Optional
0-5 VDC Output Per Channel 1-8
(Switched ON / Off - Hand Transmitter)

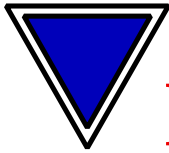

Wizard - 12 Servo Travel Adjustment

Set - Up / Servo Travel

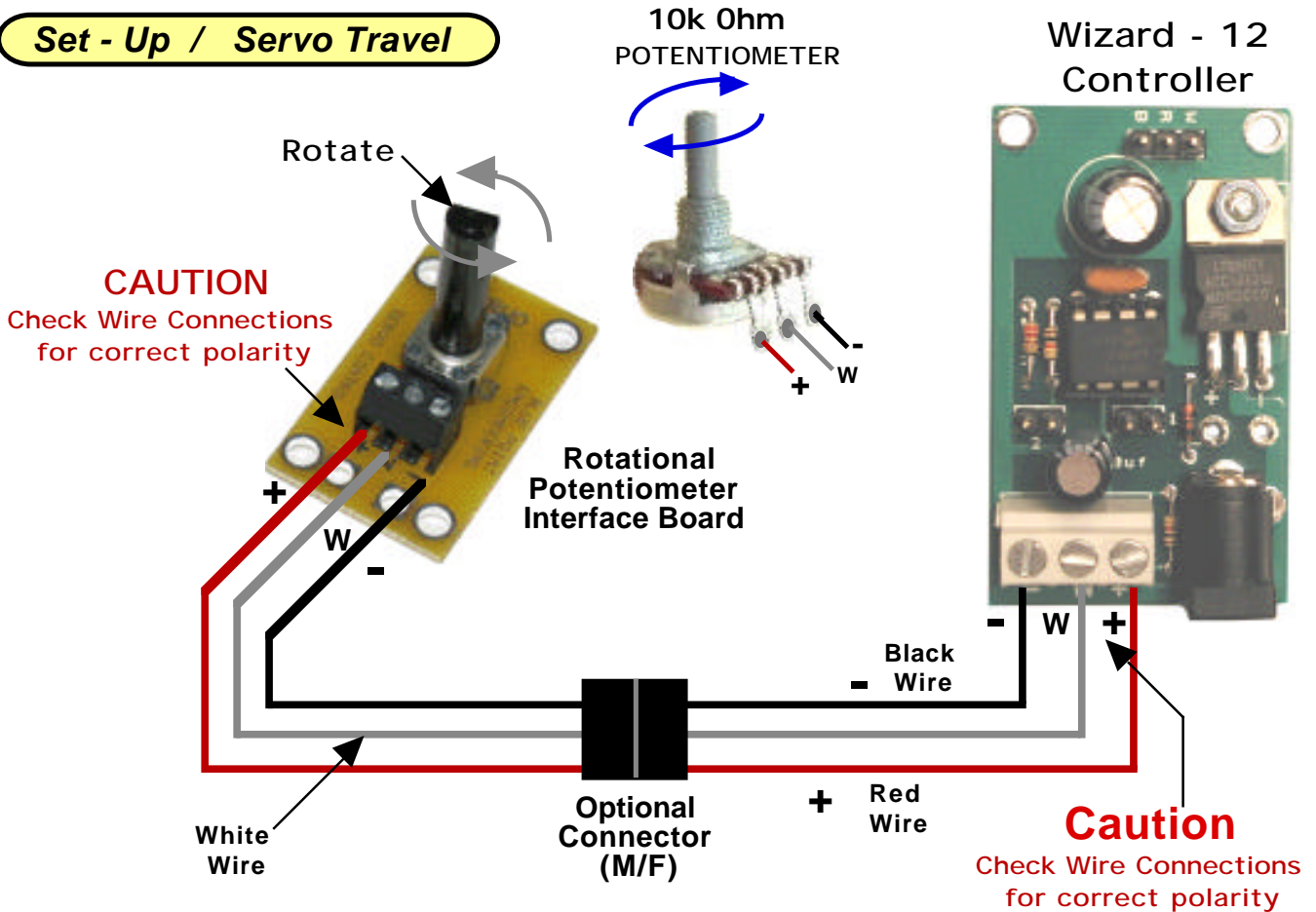

Power Connection

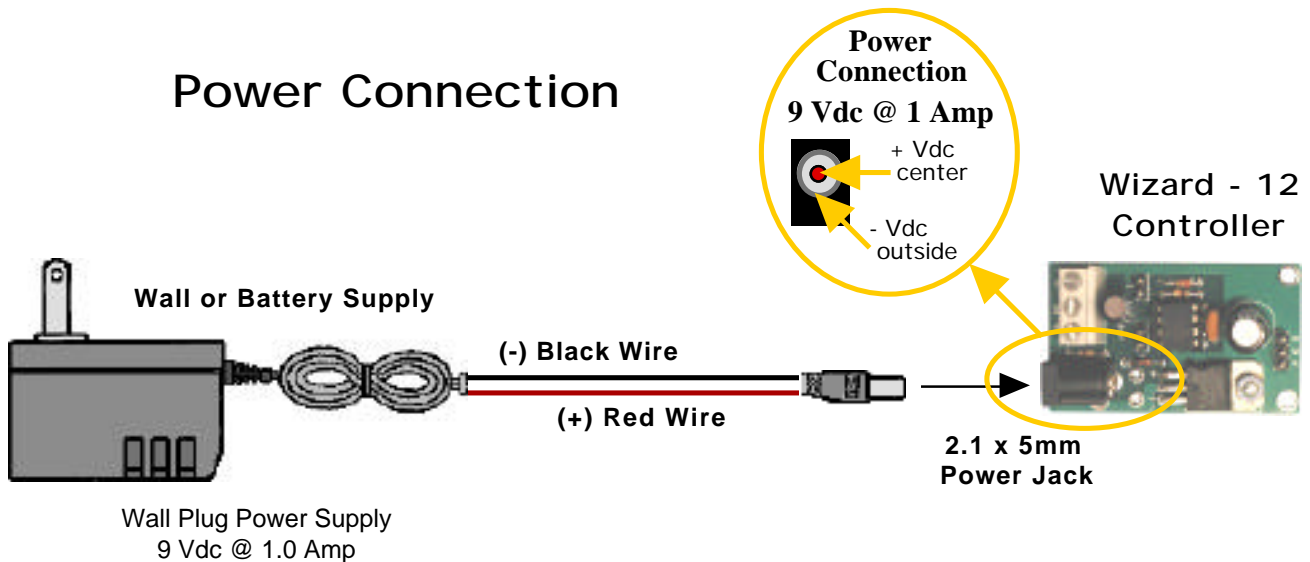

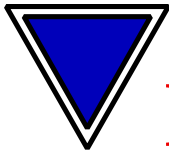

Wizard - 12 Servo Travel Adjustment

Set - Up / Servo Travel

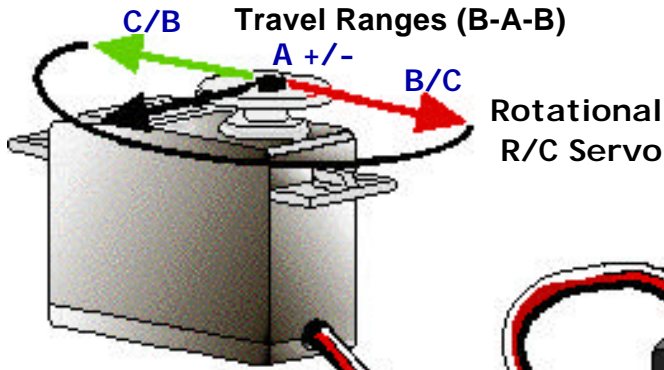

See Servo Travel Calibration guide on using the Jumper Blocks for setting the Upper and Lower Servo Travel Movements

Caution
Check Correct Servo Connection

Analog Servo

W Servo (S)
R Servo (+)
B Servo (-)

White
Red
Black

R/C Servo Connection

BRW

JP2 Configuration

JP1 Configuration

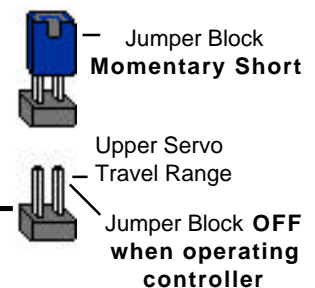
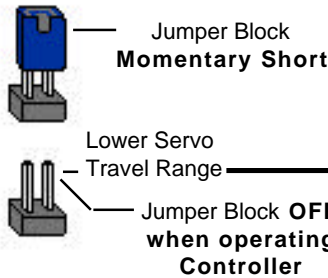

POTENTIOMETER

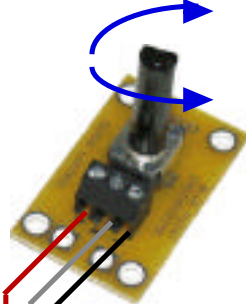

Caution
Potentiometer Connection Terminal

Power Connection
2.1 x 5mm Power Jack

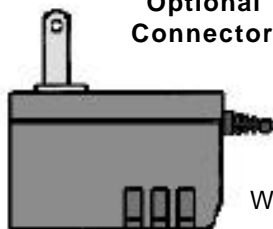

Wall Plug Power Supply
9 Vdc @ 1.0 Amp

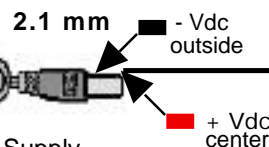

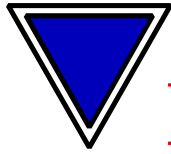

Wizard - 12 Servo Travel Calibration

Servo Travel Calibration

Connect a potentiometer, servo and power supply to the Wizard-12 controller board.

Adjusting the potentiometer will control the position of the attached servo. The full range of the potentiometer and board electronics will generate pulse width equivalent to a 180-degree servo movement. (1ms - 2ms) Some servos will not accommodate this movement range. so take care not to drive the servo into its limit stops at the extreme setting range.

Setting the Servo Movement / Travel Range

Upper Limit Range:

Adjust the potentiometer and move the servo output travel to the upper range point that you want the servo to stop at. Temporarily short the **JP1** pin pair set by placing the jumper onto the pin pair for a few seconds, then remove the jumper. This will record in memory the upper movement travel range limit. This setting will be retained even after the power is turned off, and will stay in memory until manually reset to a new range.

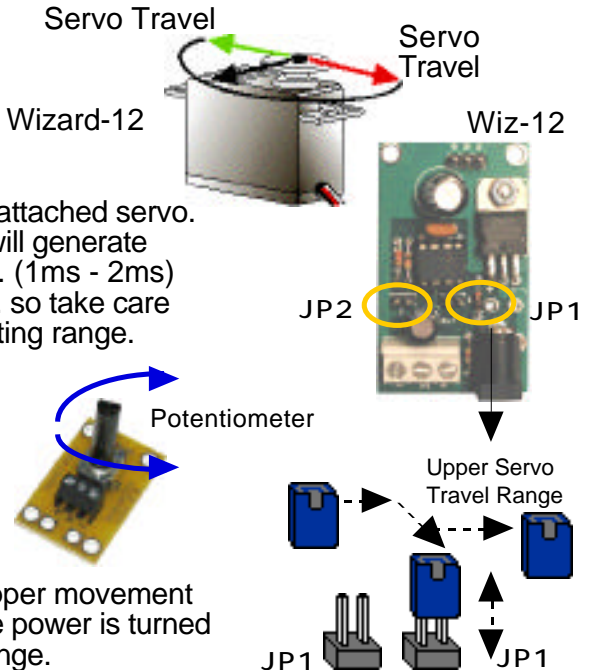

Lower Limit Range:

Adjust the potentiometer and move the servo output travel to the lower range point that you want the servo to stop at. Temporarily short the **JP2** pin pair set by placing the jumper onto the pin pair for a few seconds, then remove the jumper. This will record in memory the upper movement travel range limit. This setting will be retained even after the power is turned off, and will stay in memory until manually reset to a new range.

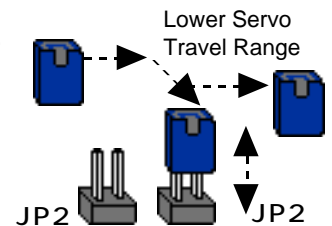

Note: If the servo does not move as the potentiometer is adjusted, it may be that the upper and lower limit travel ranges are overlapping. Try re setting the limits again or **RESET** the limit settings and start again with the servo limits

To RESET the Servo Lower and Upper Travel Limit Ranges:

Temporarily short **JP1** pin pair set or **JP2** pin pair set by placing a jumper onto the pin pair for a few seconds, then remove the jumper. This will reset the servo movement travel limit values recorded in memory to a 0 value allowing the servo to move the full travel range of the servo.

(Note: some servos move only small travel ranges, as manufactured. For max travel, select a servo that has the desired travel ranges you need)

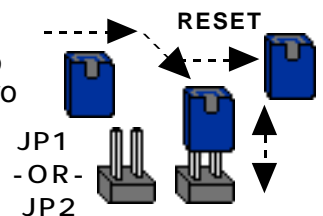

Troubleshooting:

Q. I am having trouble getting the servo to move when I adjust the potentiometer.

A1. Reset the Servo Lower and Upper Limit Ranges:

Temporarily short JP1 pin pair set or JP2 pin pair set by placing a jumper onto the pin pair for a few seconds, then remove the jumper.

A2. Check to see that the Potentiometer has been wired correctly to the control board terminal block. Wires +, - and W. Does the Wizard-12 board have power?

A3. Check to see if the servo is designed to move only a set amount (See servo information specifications from manufacture on servo)

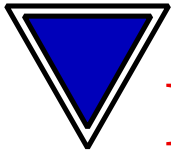

RX-8 RF System RF Handheld Modules

Set - Up / Changing Address

Long Range Handheld Transmitter

The RF Long Range Handheld Transmitter allows the selection of one of 16,777,216 (2^{24}) unique addresses. All Transmitters come ready to go with an address preset. To avoid conflict with other units or to create your own unique address or add additional RF Receiver boards, you will need to change the RF handheld Transmitter and RF Receiver board address.

RF Long Range Handheld Transmitter

Using a paper clip, press the CREATE button down on the RF handheld Transmitter through the hole in the back of the case. A LED will now light up indicating that the new address is being created. The address will be randomized for as long as the button is held down. Release the button and the new randomized address will be activated. The LED will begin flashing to indicate that the Control Permission Buttons access may now be set. Press the buttons 1-8 on the front of RF handheld transmitter. Press the CREATE button with the paper clip again to record you actions. A new button address and Control Permissions are now set in the RF handheld Transmitter. The RF Receiver board will now need to learn the address before it will accept any handheld button transmissions.

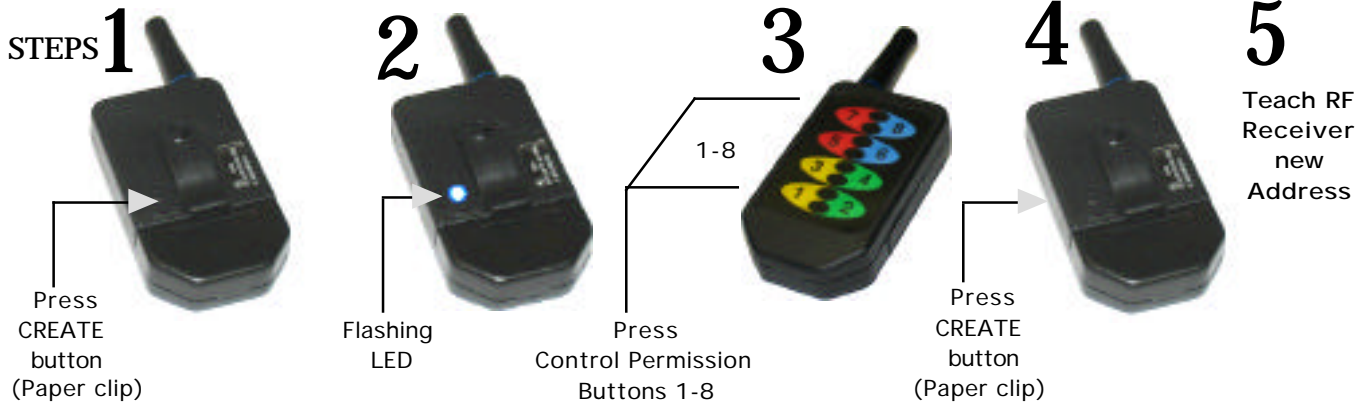

RF Receiver Board - 8 Channel

Press the LEARN button down momentarily on the RF Receiver board. The Yellow LED will begin flashing indicating that the Receiver board is ready to learn the new handheld Transmitter addresses. Press buttons 1-8 on the front of the RF handheld Transmitter. Press the LEARN button down momentarily on the RF Receiver board again to record the actions of the handheld Transmitter buttons. The RF Receiver board is now ready to recognize the handheld Transmitter buttons and turn on the corresponding output channels 1-8 when activated by the handheld Transmitter. Test the system by pressing a button on the RF handheld Transmitter; a corresponding output on the RF Receiver board should be activated 1-8 (LED- Green ON).

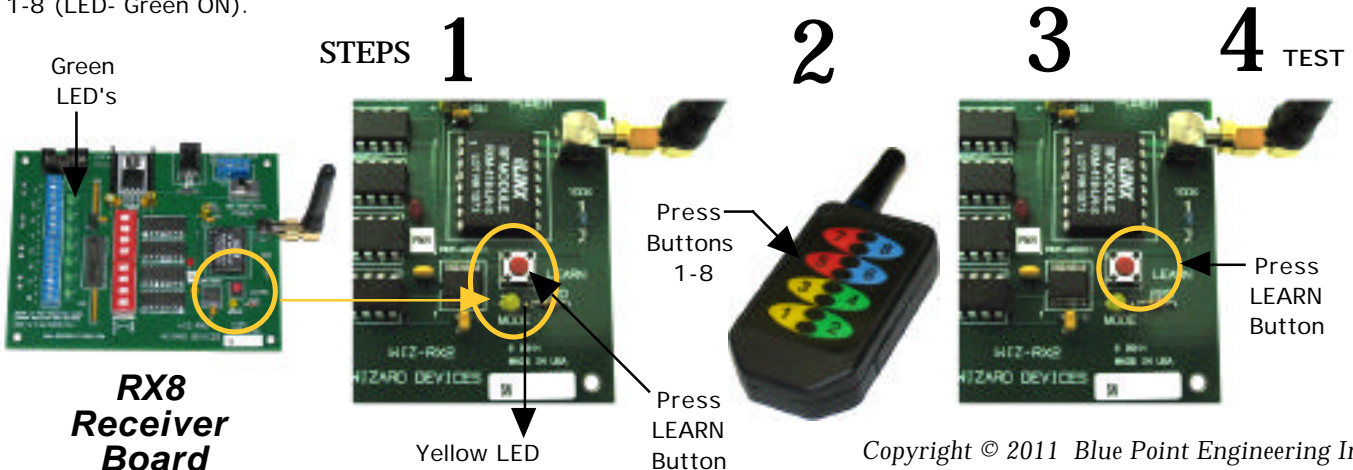

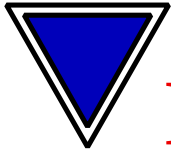

RX-8 RF System RF Handheld Modules

Set - Up / Battery - Transmission

BATTERY REPLACEMENT

The LR remote unit utilizes a standard CR2032 Lithium Button Cell . In normal use, it will provide 1 to 2 years of operation. To replace the battery, remove the access cover by pressing firmly down on the area and sliding it off. Once the unit is open, remove the battery by sliding it from beneath the holder. There may be the risk of explosion if the battery is replaced by the wrong type. Replace it with the same type of battery while observing the correct battery +/- polarity.

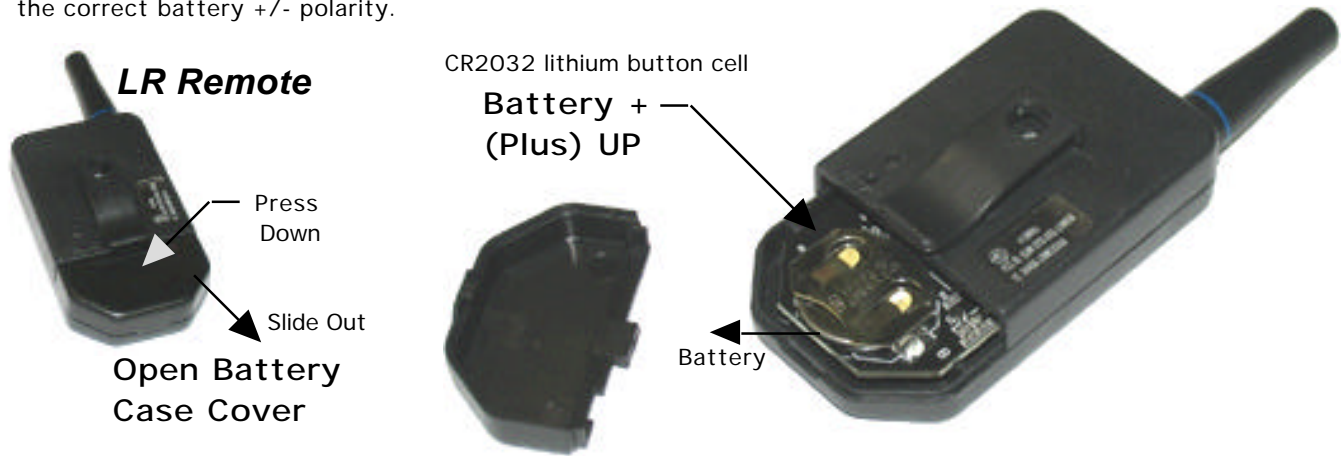

RF Transmitter and Receiver CONSIDERATIONS

Only one Transmitter at a time can be activated within a reception area. While the Transmitted signal consists of encoded digital data, only one carrier of any particular frequency can occupy airspace at any given time. If two identical Transmitters are activated in the same area at the same time, then the signals will interfere with each other and the decoder will not see a valid transmission if the address is the same. **NOTE:** Two Receiver boards or more can be activated at the same time and share a common RF handheld Transmitter address or two Transmitters of different addressing and associated Receiver boards can be used in the same reception area with no interference issues usually.

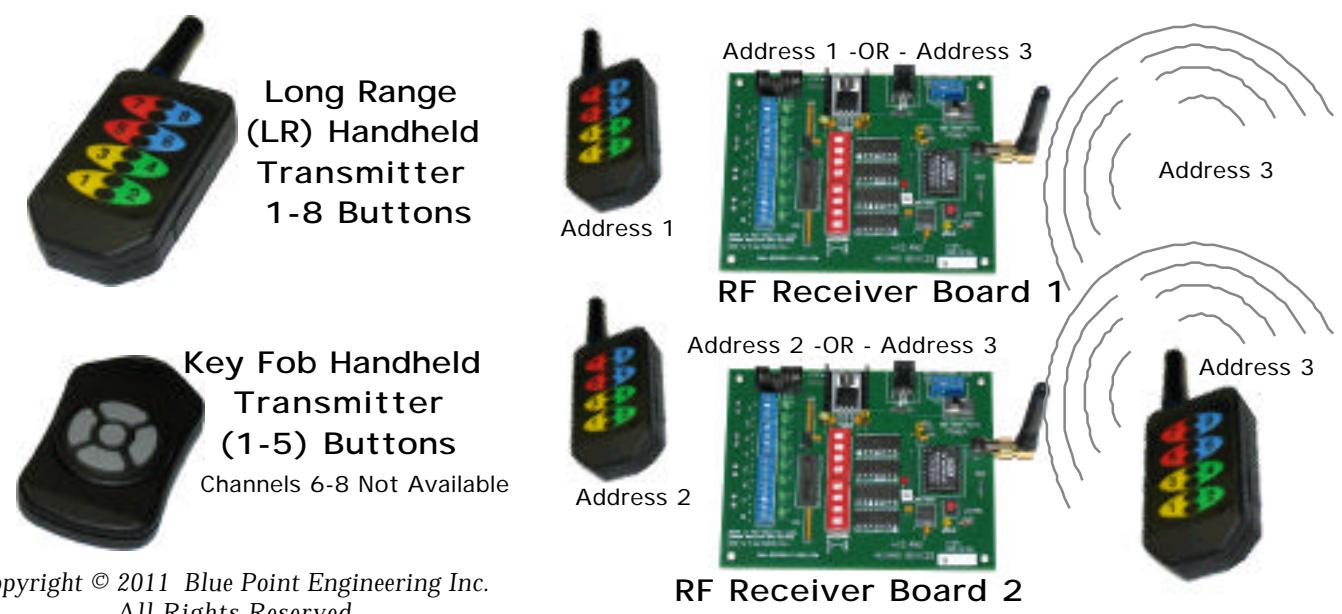

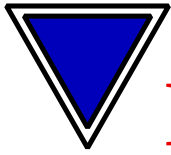

RX-8 RF System RF Handheld Modules

Set - Up / Changing Address

Key Fob Handheld Transmitter

The RF Key Fob Handheld Transmitter allows the selection of one of 16,777,216 (2^{24}) unique addresses. All transmitters come ready to go with an address preset. To avoid conflict with other units or to create your own unique address or add additional RF receiver boards, you will need to change the RF handheld Transmitter and RF receiver board address.

RF Key Fob Handheld Transmitter

Using a paper clip, press the ADD button down on the RF handheld Transmitter through the hole in the back of the case. The address will be randomized for as long as the button is held down. Release the button and the new randomized address will be activated. Press the buttons 1-5 on the front of RF handheld Transmitter. Press the ADD button with the paper clip again to record you actions or wait 17 seconds for it to time out. A new button address and Control Permissions are now set in the RF handheld Transmitter. The RF Receiver board will now need to learn the address before it will accept any handheld Key Fob button transmissions 1-5.



RF Receiver Board - 8 Channel

Press the LEARN button down momentarily on the RF Receiver board. The Yellow LED will begin flashing indicating that the Receiver board is ready to learn the new handheld Transmitter addresses. Press buttons 1-5 on the front of the RF handheld Transmitter. Press the LEARN button down momentarily on the RF Receiver board again to record the actions of the handheld Transmitter buttons. The RF Receiver board is now ready to recognize the handheld Transmitter buttons and turn on the corresponding output channels 1-5 when activated by the handheld Transmitter. Test the system by pressing a button on the RF handheld Transmitter; a corresponding output on the RF Receiver board should be activated 1-5 (LED- Green ON). NOTE: LED's 6-8 and Channels 6-8 Not used with Key Fob Transmitter

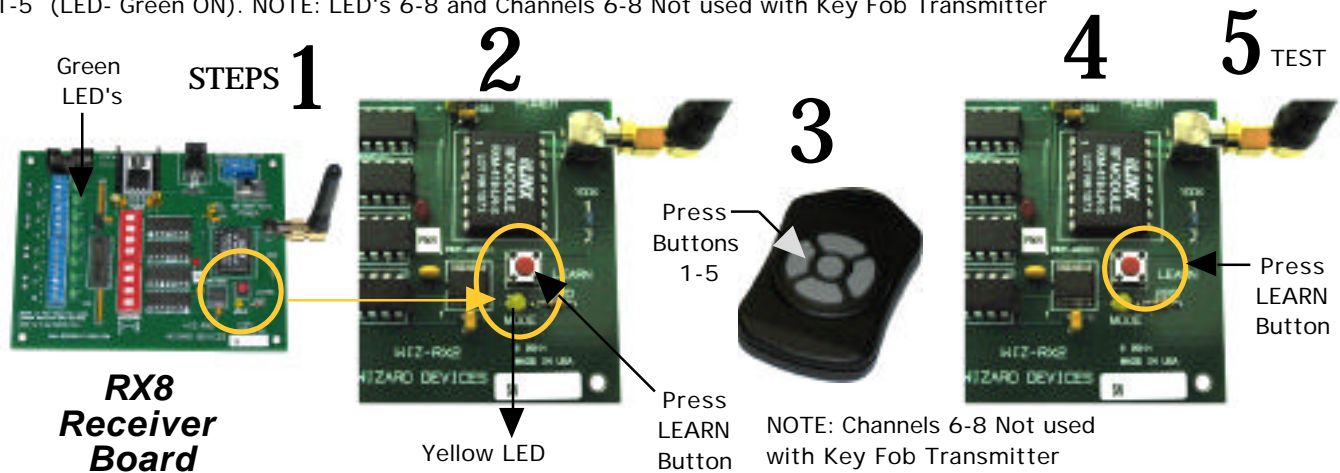

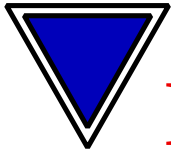

RX-8 RF System RF -Transmitter 418MHz

FCC Compliance, Certification

INSTRUCTION TO THE USER

FCC compliance

This device complies with Part 15 of the FCC Rules.

Operation of this device is subject to the following two conditions:

- (1)** This device may not cause harmful interference, and
- (2)** this device must accept any interference received, including interference that may cause undesired operation.

This equipment has been tested and found to comply with the limits for a Class B digital device, pursuant to Part 15 of the FCC Rules. These limits are designed to provide reasonable protection against harmful interference in a residential installation. This equipment generates, uses and can radiate radio frequency energy and, if not installed and used in accordance with the instructions, may cause harmful interference to radio communications. However, there is no guarantee that interference will not occur in a particular installation. If this equipment does cause harmful interference to radio or television reception, which can be determined by turning the equipment off and on, the user is encouraged to try to correct the interference by one or more of the following measures:

Reorient or relocate the receiving antenna.

Increase the separation between the equipment and receiver.

Connect the equipment into an outlet on a circuit different from that to which the receiver is connected.

Consult the dealer or an experienced radio/TV technician for help.

This equipment has been certified to comply with the limits for a Class B computing device, pursuant to FCC Rules. In order to maintain compliance with FCC regulations, shielded cables must be used with this equipment. Operation with non-approved equipment or unshielded cables is likely to result in interference to radio and TV reception. The user is cautioned that changes and modifications made to the equipment without the approval of manufacturer could void the user's authority to operate this equipment.

Long Range Handheld RF Transmitter (8 CH)

FCC ID: OJM-OTX-XXX-LRMSA

IC: 5840-LRMS-XXXX



418MHz

Key Fob Handheld RF Transmitter (5 CH)

FCC ID: OJM-OTX-XXX-KFMSA

IC: 5840A-KFMS-XXXX



418MHz