

R/C Servo to Analog Converter Board

Controller

This servo-analog converter board provides a two channel capability of converting standard R/C servo PWM pulses to 0-10 Vdc and/or 0-5 Vdc outputs suitable for driving standard lighting dimmer packs or any device that requires a 0-5 and / or 0-10 Vdc variable controlled analog signal input.

**Board Size:****3-5/8" L x 1-1/4" W x 3/4" H****Specifications:**

- Servo input pin headers from R/C unit.
- **2 - Channel** Analog 0-5 and/or 0-10 Vdc DC output is available from the 4 way terminal block for wire connection.
- No external power supply is required, the module takes it's supply from the incoming servo drive connections.
- Servo inputs: 1 to 2msec pulses.
- **1-msecs servo pulse gives 0 V DC output.**
- **2-msecs servo pulse gives 5 or 10 VDC output.**
- 0-5 and/or 0-10 Vdc DC Analog outputs in **80mV increments.**
- Adjustable Resistor variable voltage ranges 0 - 10 Vdc Outputs.
- **125 steps** between 0 and 10 Vdc available.
- **Maximum driver current is 10mA per Channel.**
- Small Board Size: 3-5/8" L x 1-1/4" W x 3/4" H

Connections:

Connect servo plugs from input 1 and 2 on the 3-pin headers marked Servo 1 and Servo 2, to a servo controller board or R/C receiver servo channels. **Ensure the wire polarity is correct.**
(R=+5v, B=Ground, Y=Signal) / (R=Red, B=Black, Y=Yellor or White Wire)

Note: the board has corresponding wie holes, if you want to solder the servo wires to the board directly. Carefully pull-away the rubber backing from the board, place the wires through the correct hole and solder. Ensure the wire polarity is correct.

Analog Range 0-5 and / or 0-10 output is available from the 4-way terminal block.

Power Supply

No external power supply is required. The module takes its power from the incoming servo drive connections.

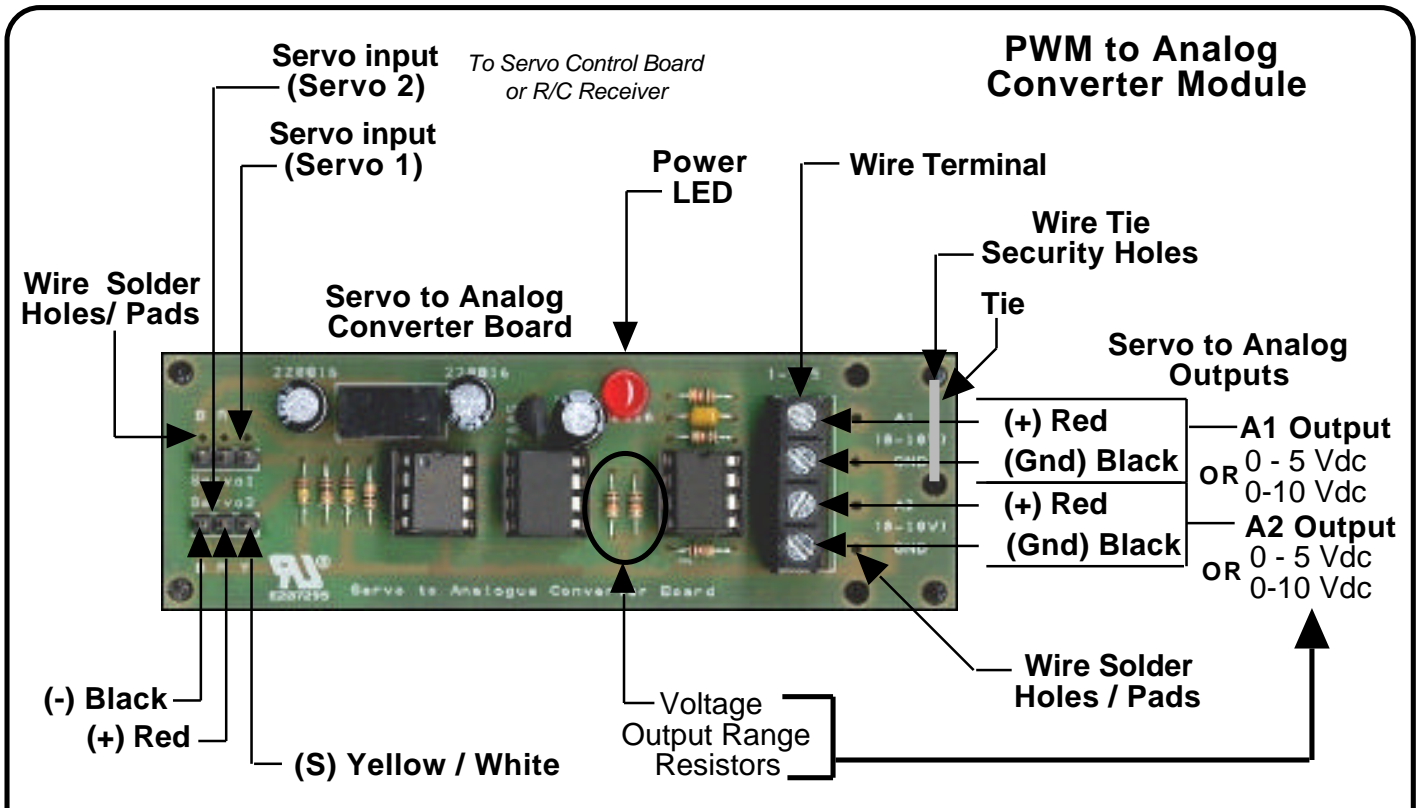

R/C-Servo PWM to Analog Converter Module Application

R/C System

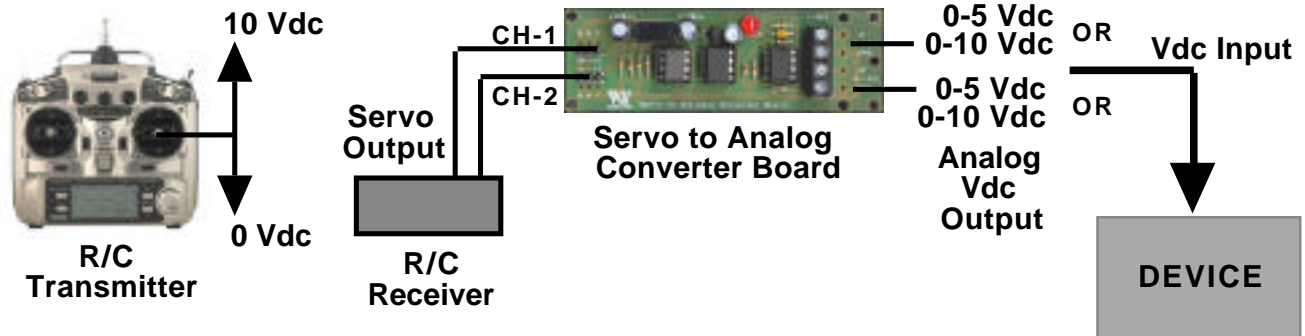

Wizard Control Board Connection

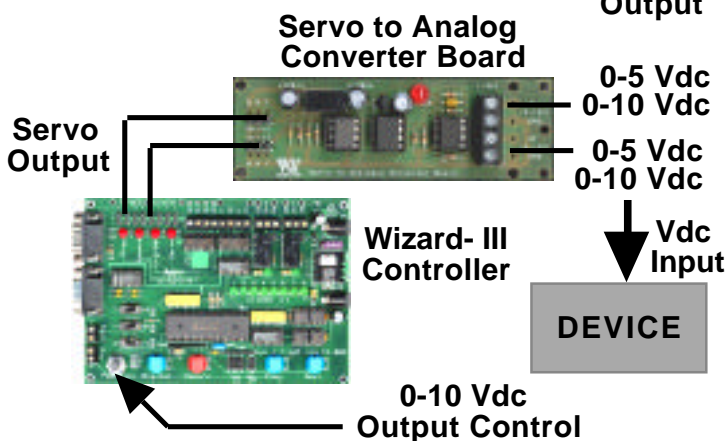

Puppet Control Board Connection

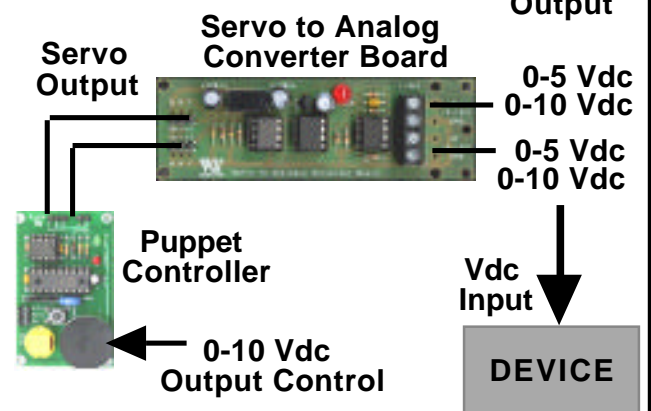

Changing the Voltage Output Range (0-5 / 0-10 or other Values)

The voltage output range may be modified from 5 Vdc up to a maximum of 10Vdc.

The output voltage is determined by the following equation:

$$\text{Maximum Voltage Output} = 5 \times [1 + 10 / R_A]$$

Where R_A is expressed in k ohms

As supplied, R_A is 10k so the maximum output is 10 Vdc

Removing, R_A will limit the maximum output to 5 Vdc

Replacing, R_A with a 20k resistor will limit the maximum output to $5 \times [1 + 10/20] = 7.5$ Vdc

R_A may be a different value (output Vdc) for each channel.

R_A for each channel is shown below.

Servo to Analog Converter Board

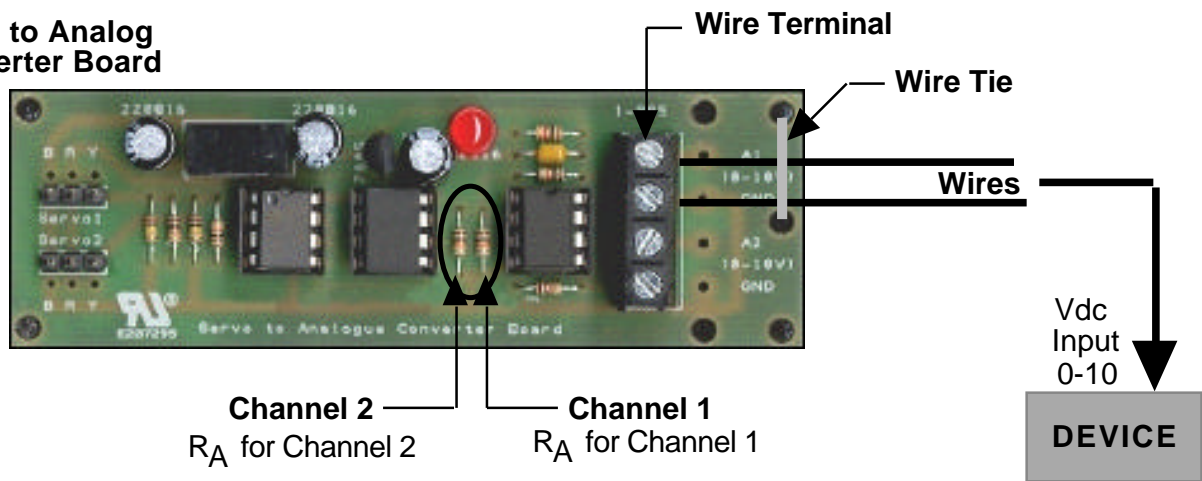

Servo to Analog Converter Board

Servo to Analog Converter Board Output Example

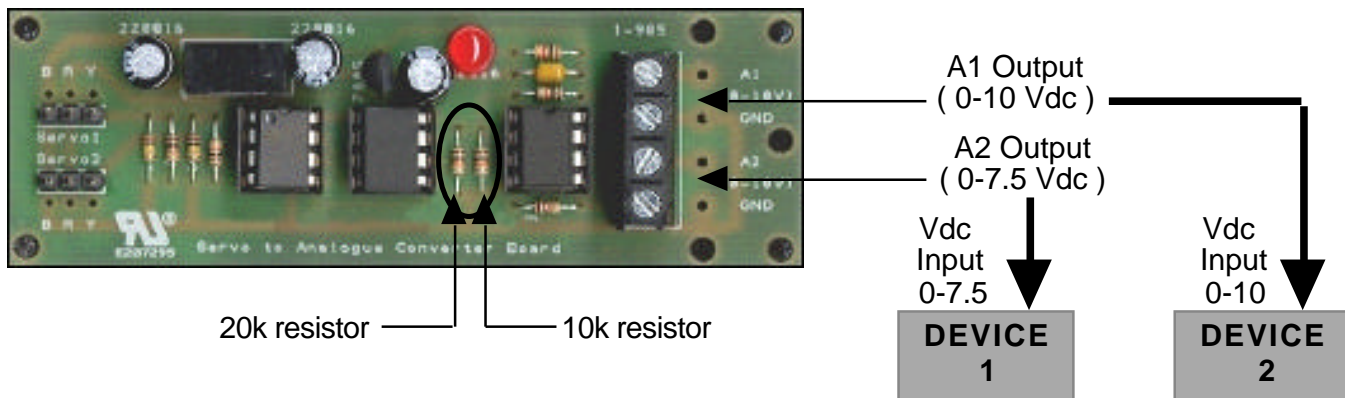

Custom Equipment, Unique Electronic Products

Blue Point Engineering

www.BPEsolutions.com

Phone (303) 651-3794