

## Wizard - 5 Board

Controller

Page 1

The **Wizard 5 Board** will record and playback up to **5 minutes** of motion for up to 2 servos and On and Off relay action for 2 digital outputs. It also incorporates a **4-minute** audio recording and playback IC sound chip with the option to control one servo channel from recorded moves, from an input audio signal or directly from the on-board sound IC chip.

The board includes features such as looping action with variable delay between loops, auto start-up on power up and a connection terminal for a PIR, remote switch or sensor to initiate playback start.

Recording sessions are built up on a simple channel-by-channel method using on-board switches and potentiometer control. No computer or complex programming is required to operate board. During recording, all previously recorded channels are re-played to aid synchronization.

### WIZARD - 5 BOARD FEATURES:

- 2 Digital channels - either 0 / 4.5 Volts @ 10mA outputs or change over relay rated 30V @ 2 Amp.
- 2 Servo channels – one channel may be automatically controlled from an audio signal either from the line input or from the on-board sound chip.
- 4 minute high quality sound chip - digital recording from line input ( Computer sound card, CD player, etc.).
- Digital ON-OFF, NEXT, PLAY and RECORD on-board buttons.
- Servo action reversing option on the audio channel servo - 2
- Maximum and minimum servo travel set points for the audio servo channel - 2
- 2 - selectable on-board relays ( 2 Amp @ 30 Volts dc ).
- Relays have insert wire terminal connection blocks.
- 2 - direct Digital control signal 0 / 4.5 Volts dc -10 mA connection pads, for hard wiring to board outputs.
- On-board potentiometer to determine the time delay between playback loops during automatic loop play, fully adjustable between 0 and 65 seconds.
- Record enable / disable jumper to protect recorded programming routine.
- On-board AUTO-PLAY and LOOP-PLAY switches.
- Battery remote operation or wall power operation.
- Remote terminal block activation connection for manual start switch, pressure mat or PIR sensor.
- Programming and operation Green and Red status LED's.
- EEPROM - containing the programmed data, can easily be removed and copied to other Wizard - V boards.
- Synchronization output signal to activate other Wizard boards linked together.
- Board is powered from regulated 9 Volts dc power supply or can be run from optional Remote Battery operation for mobile setup.
- REMote - board trigger input from remote sensor with H or L signal activation jumper.
- Many more unique features.

### Board Functions:

**Position Potentiometer** - Servo motion, Time delays

Adjusts the position of the currently selected servo travel ( Channel 1 and 2)

Sets the audio channel end stops.

Sets the time delay between playback in loop-play, adjustable to between 0 to 65 seconds.

### WIZARD - 5 BOARD

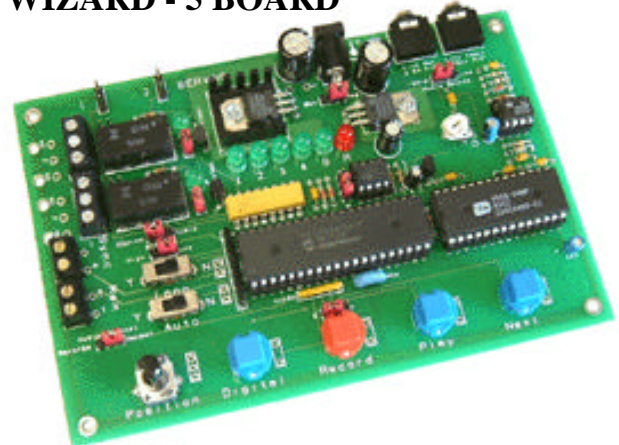

Board Size: 6" L x 4" W x 3/4"H

Wizard - 5 Board is pre-assembled and tested.  
Regulated 9 Volt dc power supply @ 2 Amp  
power supply required

**Digital** - On / Off -key

Pressing the Digital key will activate the current channel selected (ch -3 and 4) output relay as ON or OFF. This is a momentary switch. Press and hold the Digital key, when you want the relay to be ON, release OFF.

**Relay** - N.C, C, N.O connections.

N.C = Normally Closed position of the relay contacts ( Circuit is ON- will open circuit (OFF) when activated )

C = Common connection to relay contacts

N.O = Normally Open position of the relay contacts ( Circuit is OFF- will close circuit (ON) when activated )

**Relay / Pin Output Jumpers.** When this jumper is in place, the board will control the on-board relays. The relays are rated at 30 V @ 2 Amp. When the jumper is removed, the relay is de-activated and the output pins may be used as voltage drivers ( 0 Vdc or 4.9 Vdc @ 100mA when on). The pins are marked with Plus (+) and Minus (-) for correct polarity connection. Use caution when connecting to the pins to observe correct polarity (+ / - )

**Play** - key

Replays a set of recorded relay actions.

During play back the channel LED's will form a bar-graph indicating the amount of time used.

When the recorded routine has finished playing the bar-graph-LED's will go out.

A switch, sensor may be connected to the REM connection and this will function in the same way as the Play-key.

**Next** - channel key (servo 1-2, Relay 3-4, sound IC chip)

Changes the current active channel to the next channel.

Each key-press selects the next channel - servos 1 and 2, digital 3 and 4 and the sound chip.

**Record** - key (Servos, Relays and Sound IC)

The record - key has no effect unless enabled by the record-enable E/D Jumper. (see drawings for details)

Press and release the record key to start recording a routine. Press and release the Record-key to stop recording. If the Record-key is held down when power is applied to the board, all memory will be erased.

(Takes approximately 20 seconds, LED will form a bar-graph indicating EEPROM erasing is occurring.).

During the recording of a channel the LED's will form a bar-graph indicating the amount of time being used.

When the action has finished playing the bar-graph-LED's will turn off.

**RECORD NOTE:**

The recording on channel -1 will set the maximum available recording time for all other channels.

Always record channel -1 first, then the other channels ( 2-4 ). Recording periods for channels 2-4 cannot be longer than for channel -1.

**D / E Jumper** - EEPROM Protect.

The Record / Enable jumper protects the programmed routine in the EEPROM. If the jumper is set at the "E" enable position then recording will be permitted. Move the jumper to "D" disable recording to prevent recording to the EEPROM. The Record button E/D jumper will enable or disable button from operating.

**SYNC Terminal** - Output

Synchronizing connection for multiple board to be linked together. On-board terminal connection delivers a pulse signal (50 msec) at the start of playback and record event which may be used to trigger other Wizard boards connected in a chain or master module - slave module setup. SYNC output to REM input of other boards.

**REMOte Terminal**

Used to trigger Wizard board by remote switch, sensor. Can also be wired together for no-stop playback.

**REM Jumper** - H and L positions. ( Sensor N.O. or N.C. relay input option)

To begin playback when the input line drops from + to ground, set the REM jumper to the L position. To begin playback when the action input goes from ground to + (sync pulse) set to the H position

**LOOP** - slide switch.

To make the Wizard - V board play the recorded moves repeatedly, move the switch to the "Y" position. The recorded moves will start to play when the PLAY-key is first pressed. There will be a pause at the end of playing (determine by the position of the **Loop Delay** control) after which the recorded action will start again.

Note: To record new program routines, the LOOP switch must be set to the "N" position.

**LOOP** - delay.

**Pause between playback loop option.**

When the Wizard - V board is set to the **LOOP "Y"** position, the length of the pause between repeated playbacks may be set by the on-board **Loop Delay** control potentiometer.

Turn the **Loop Delay** control counter clockwise (CCW) for the minimum delay (approximately 2 seconds and clockwise for the maximum delay (approximately 65 seconds).

**AUTO** - slide switch.

To make the Wizard - V board play the recorded moves repeatedly on power - ON or reset, move the switch to the **"Y"** position. The recorded actions will start to play on any power-up.

Note: to record new program moves, the AUTO switch must be set to the **"N"** position.

**Servo 2 - Options** (Programmed movement or Auto - Sound to Motion)

Set the jumper (**Servo - 2**) to the **EEPROM** position to record and playback moves in a similar manner to Servo Channel 1. (Programmed motion)

Set the jumper to **Audio** to control the movement of Servo - 2 from an audio signal (line in or from sound chip) When set to audio, the audio signal generated by either the on-board sound chip or a suitable line input signal is sampled and used to control the servo movement. This feature is particular useful for "Mouth" servo operation as it requires no special user programming synchronization needed with a sound source. Use the Audio Source jumper to select from the on-board sound **Chip** or the **Line** input jack.

**Using Servo - 2 with an Audio Control Signal** (sound ic or line input source)

**Setting Servo - 2 travel end points**

Select the required audio source (On-board chip or line input jumper)

Set the servo travel end points for servo - 2. Press and hold the **NEXT** key and apply power to the board.

LED -1 will start to flash and servo - 2 can be controlled by the **Position** potentiometer. Move the servo to one end point of the required servo travel range. Press the **Digital** button.

LED -2 will now flash - adjust the servo position to the other end of the servo limit and press the **Digital** button.

LED -2 will now turn off and the control board will return to a normal operation mode ( LED-1 will turn on).

The two servo limit travel points have been stored in memory and will limit the travel of Servo -2 when responding to an audio signal.

The degree of Servo - 2 movement is governed by the combination of the sound source volume and the Gain presets. Rotate the **Gain** potentiometer on-board, clockwise for maximum signal gain and maximum servo movements.

**Audio Channel - Reverse / Normal Jumper**

Setting the jumper to the **Reverse** position will cause the motion of Servo - 2 to be reversed (operate in the opposite direction currently moving)

**Audio Setting**

**INPUTS** - ( 150 mVolts P-P Level )

Line Input - audio source going into the Wizard - V board (CD player, computer, stereo, etc.), usually to be recorded to the Sound IC chip, or to drive Servo - 2 directly.

**OUTPUTS** - ( 2.5 Volts P-P Level )

Line Output - audio from the on-board sound chip going out to a remote external powered speaker or amp system. The audio from the sound IC chip is slightly amplified to operate an 8 Ohm speaker directly only for playback audio review. In normal use the audio output should be connected to a remote external powered speaker or amp for best sound results and volume.

**Clearing Memory to start a new program.**

The Enable jumper must be set at the **(E)** position and the Record-key jumper also set to the **(E)** position.

The LOOP switch and the AUTO switch must be in the **"N"** position.

The **RECORD - key** is held down during Power Up, and released after power is applied.

The LED's "1-4" will form a count down bar-graph indicating that current programmed EEPROM memory is being cleared. (This will take approximately about 20 seconds).

After the initial 20 seconds all green LED's "1-4" will turn OFF and the current selected channel LED will turn ON, indicating the board is now ready for new programming.

**BAT and REG Jumper.**

When operating the board from a regulated wall power supply the jumper should be in the REG position.

When powering the board from a remote battery, jumper in the BAT position. Board holes + ( **Plus** ) and - ( **Minus** ) connections When powering the board from a battery supply, the wires can be soldered to these holes for a more permanent connection. Observe polarity + and - to prevent damaging the board.

## Examples

### 1. *Recording - Servo Motion and Relay Action On and Off - New program start*

Make sure that the EEPROM E/D jumper is set at the (E) position and that the Record key -E/D jumper is also set to the (E) position. The LOOP and the AUTO switch must be in the "N" position.

Power down the Wizard -V controller and then hold down the record key and apply power back to the board, all memory will be erased (LED's will count down, approximately 20 sec.)

Select Servo Channel -1 by pressing **NEXT**-channel-key until the green number 1 - LED is ON.

Press and release the **RECORD**-key. (The red LED will turn ON, record mode is now active)

Adjust the **Position** Potentiometer, moving Servo - 1 as needed. ( approx. 2 minutes)

Press and release the **RECORD**-key to end recording session and set total record time (5 Min Max).

Select Relay - 1 Channel by pressing **NEXT**-channel-key until the green number 3 - LED is ON.

Press and release the **RECORD**-key to start recording session for relay.

Press and hold the **Digital** - key for approximately 1 minute, then release the **Digital** key switch.

Relay - 1 will turn **On** and **Off**, as you press and release Digital key.

( Note: Servo Channel -1 will playback previously recorded action to help in synchronization of the new channels being recorded )

The recording will **end automatically** after approximately 2 minutes ( established by channel - 1 recording time used )

#### *Playback of Recorded Program Servo Channel -1 and Relay -1*

Press and release the **PLAY**-key to review the recorded sequences.

Relay -1 and Servo Channel -1 will playback recorded actions, then wait for **PLAY**- key to be pressed again.

#### *Programming Servo - 2 as a Recorded Routine.*

Make sure that the EEPROM / Audio jumper is set at the (**EEPROM**) position and that the EEPROM E/D jumper and the Record key jumper is also set to the (E) position. The LOOP and the AUTO switch must be in the "N" position.

Select Channel -2 by pressing **NEXT**-channel-key until the green number 2 - LED is ON.

Press and release the **RECORD**-key. (The red LED will turn ON, record mode is now active)

Adjust the **Position** Potentiometer, moving Servo - 2 as needed.

( Note: Relay -1 and Channel -1 will playback previously recorded action to help in synchronization of the new channels being recorded )

The recording will **end automatically** after approximately 2 minutes ( established by channel - 1 recording time first set).

**NOTE:** *The recording on channel - 1 will always set the **maximum** available recording time for all other channels. Always record channel - 1 first, then the other channels. Recording periods for channels 2 cannot be longer than for channel - 1. ( **Maximum recording time for servos and relays is 5 minutes**).*

## Examples

### 2. *Editing a Servo Channel* (channel -2 example)

You can re-program Servo channels 2, by pressing the **NEXT**-channel-key until Channel -2 green LED is ON.

Press and release the **RECORD**-key. (The red LED will turn ON, record mode is now active)

Adjust the **Position** Potentiometer, moving Servo - 2 as needed.

The recording will end automatically based on Channel -1 recorded time.

Remember that Channel -1 sets the maximum time for all the channels. if you re-program Channel -1 with less time than previously recorded, all the other channels will also be adjusted to meet the length of Channel -1 record time if longer times were originally recorded for them.

If re-programming Channel -1, then you will need to **always press** and release the **RECORD**-key, a **second time**, after re-programming Channel - 1 to end the programming sequence, and set record time line.

### 3. *Editing Relay Channel - 1*

You can re-program Relay Channel - 1 by selecting the **NEXT**-channel-key until Channel -3 green LED is ON. Press and release the **RECORD**-key. (The red LED will turn ON, record mode is now active)

Press and release the **Digital** - key as needed. The recording will end automatically after approximately 2 minutes ( established by Channel - 1 recording time first set)

#### 4. *Recording - To Sound IC Chip*

Make sure that the EEprom E/D jumper is set at the (**E**) position and that the **RECORD**-key -E/D jumper is also set to the (**E**) position. The LOOP and the AUTO switch must be in the "N" position.

Make sure that the Audio Source Jumper is set to the **Chip** position.

Connect a audio cable from a sound source (CD player, Computer sound port, Stereo, etc.) to the Line Input Jack on-board the Wizard - V board. ( need 150 mV P-P input from sound source to operate Wizard - V board sound system)

Select Sound Chip by pressing **NEXT**-channel-key until the green **S** - LED is ON.

Press and release the **RECORD**-key at the same time that you start sound source. (CD player, Computer sound port, Stereo, etc.), The red LED will turn ON, record mode is now active. The sound source is now being digitized into the sound IC chip. The sound recording will end automatically after 4 minutes, or you can Press and release the **RECORD**-key to stop recording sound.

#### *Playback of Recorded Program Servo Channel - 1, Relay - 1 and Sound.*

Connect an audio cable from the Line Output Jack on-board the Wizard - V to a remote amplified speaker unit. Make sure that the amplified speaker is turned on, and volume set below the mid level point to start.

Press and release the **PLAY**-key to review the recorded servo, relay and sound..

Servo Channel -1, Relay -1 and Sound will playback recorded actions and end.

Press the **PLAY**-key to be start again.

**LOOP** - slide switch.

To make the Wizard - V board play the recorded moves repeatedly, move the switch to the "Y" position. The recorded moves will start to play when the **PLAY**-key is first pressed. There will be a pause at the end of playing (determine by the **Loop Delay** control from **Position** potentiometer) after which the recorded action will start again. Note: To record new program routines, the LOOP switch must be set to the "N" position.

**LOOP** - delay (**Position** potentiometer)

**Pause between playback loop option.**

When the Wizard - V board is set to the **LOOP "Y"** position, the length of the pause between repeated playbacks may be set by the on-board **Loop Delay** control (**Position** potentiometer).

Turn the **Loop Delay** control counter clockwise (**CCW**) for the minimum delay (approximately 2 seconds and clockwise (**CW**) for the maximum delay (approximately 65 seconds +/-).

**AUTO** - slide switch.

To make the Wizard - V board play the recorded moves repeatedly on power-up or reset, move the slide switch to the "Y" position. The recorded actions will start to play on any power-up.

Note: to record new program moves, the AUTO switch must be set to the "N" position.

#### Examples

#### 5. *Operating Servo Channel - 2 in Auto Sound to Motion Mode*

##### *Using on-board Recorded Sound IC Chip to Operate Servo - 2*

Make sure that the sound IC Chip has been recorded with needed audio.

Check to see that the Servo - 2 EEprom / Audio jumper is set at the (**Audio**) position.

Check to see that the Audio Source jumper is set at the (**Chip**) position.

Set the servo travel end points for servo - 2 ( see above - *Setting Servo - 2 travel end points* )

Press and release the **PLAY**-key to playback the recorded servo, relay and sound..

Servo Channel -1, Relay -1 and Sound will playback recorded actions and Servo - 2 will operate in response to the Audio from the Sound IC Chip. (You may need to adjust **Gain** control to get servo - 2 moving).

Press the **PLAY**-key to be start again, or set the **Loop** and **Auto** slide switches to optional modes.

##### *Using External Remote Audio Source to Operate Servo - 2*

Check to see that the Servo - 2 EEprom / Audio jumper is set at the (**Audio**) position.

Check to see that the Audio Source jumper is set at the (**Line**) position.

Connect a audio cable from the remote sound source (CD player, Computer sound port, Stereo, etc.) to the Line Input Jack on-board the Wizard - V ( need 150 mV P-P input from sound source to operate)

Set the servo travel end points for Servo - 2 ( see above - *Setting Servo - 2 travel end points* )

Start the external sound source, and adjust the **Gain** control on the Wizard - V board to get Servo - 2 moving.

Press the **PLAY**-key to start playback, of Servo - 1 and Relay - 1 or set the Loop and Auto slide switches to optional modes.

## IMPORTANT NOTE: Clearing Memory

**When clearing memory, only the servo and digital output recorded actions are erased. The sound IC chip can only be cleared by re-recording over the current sound. You must re-set Servo - 2 travel end point after clearing memory each time. Servo - 2 will not respond under sound activation if you have not re-set the travel points, after doing a clear memory.**

### Clearing Memory

The Enable jumper must be set at the (E) position and the Record-key jumper also set to the (E) position. The LOOP switch and the AUTO switch must be in the "N" position.

Remove Power to the Wizard - V Board.

Hold down the **RECORD - key** and re-apply power back to the board, released after power is applied.

LED's "1-4" will form a count down bar-graph indicating that current programmed EEPROM memory is being cleared. (This will take approximately about 20 seconds).

After the initial 20 seconds all green LED's "1-4" will turn OFF and the current selected channel LED will turn ON, indicating the board is now ready for new programming.

The servo and digital

### Reset of Servo - 2 Travel End Points.

#### *Setting Servo - 2 travel end points*

Select the required audio source (On-board chip or line input jumper)

Set the servo travel end points for servo - 2. Press and hold the **NEXT** key and apply power to the board.

LED -1 will start to flash and servo - 2 can be controlled by the **Position** potentiometer. Move the servo to one end point of the required servo travel range. Press the **Digital** button.

LED -2 will now flash - adjust the servo position to the other end of the servo limit and press the **Digital** button.

LED -2 will now turn off and the control board will return to a normal operation mode ( LED-1 will turn on).

The two servo limit travel points have been stored in memory and will limit the travel of Servo -2 when responding to an audio signal.

The degree of Servo - 2 movement is governed by the combination of the sound source volume and the Gain presets. Rotate the **Gain** potentiometer on-board, clockwise for maximum signal gain and maximum servo movements.

## Problem Help Guide

- Q** I am trying to get Servo - 2 to operate from the sound IC Chip, or from a Line Input remote audio source, but the servo is not moving to any sound.
- A**
- Check to see that the Servo - 2 EEPROM / Audio jumper is set at the (Audio) position.
  - Check to see that the Audio Source jumper is set at Chip for playback from the on-board IC Chip or is set to Line for a remote audio input signal.
  - Check to see that you have a good remote sound source for Line input.
  - Check the Audio cables from the sound source to the Wizard - V Line Input Jack.
  - Check to see that the Sound IC has the recorded audio needed.
  - The degree of Servo - 2 movement is governed by the combination of the sound source volume and the Gain presets. Rotate the **Gain** potentiometer on-board, clockwise for maximum signal gain and maximum servo movements.
  - Reset new travel endpoints for Servo - 2 (See Reset of Servo - 2 Travel End Points)

# Wizard - 5 Controller Board Power Supply Overview

## Power Supply

The Wizard - V control board will work with power supplies between 9 and 12 Vdc @ 2 Amp.  
A small 2.1 mm socket with center positive is built-on board for quick power connection.

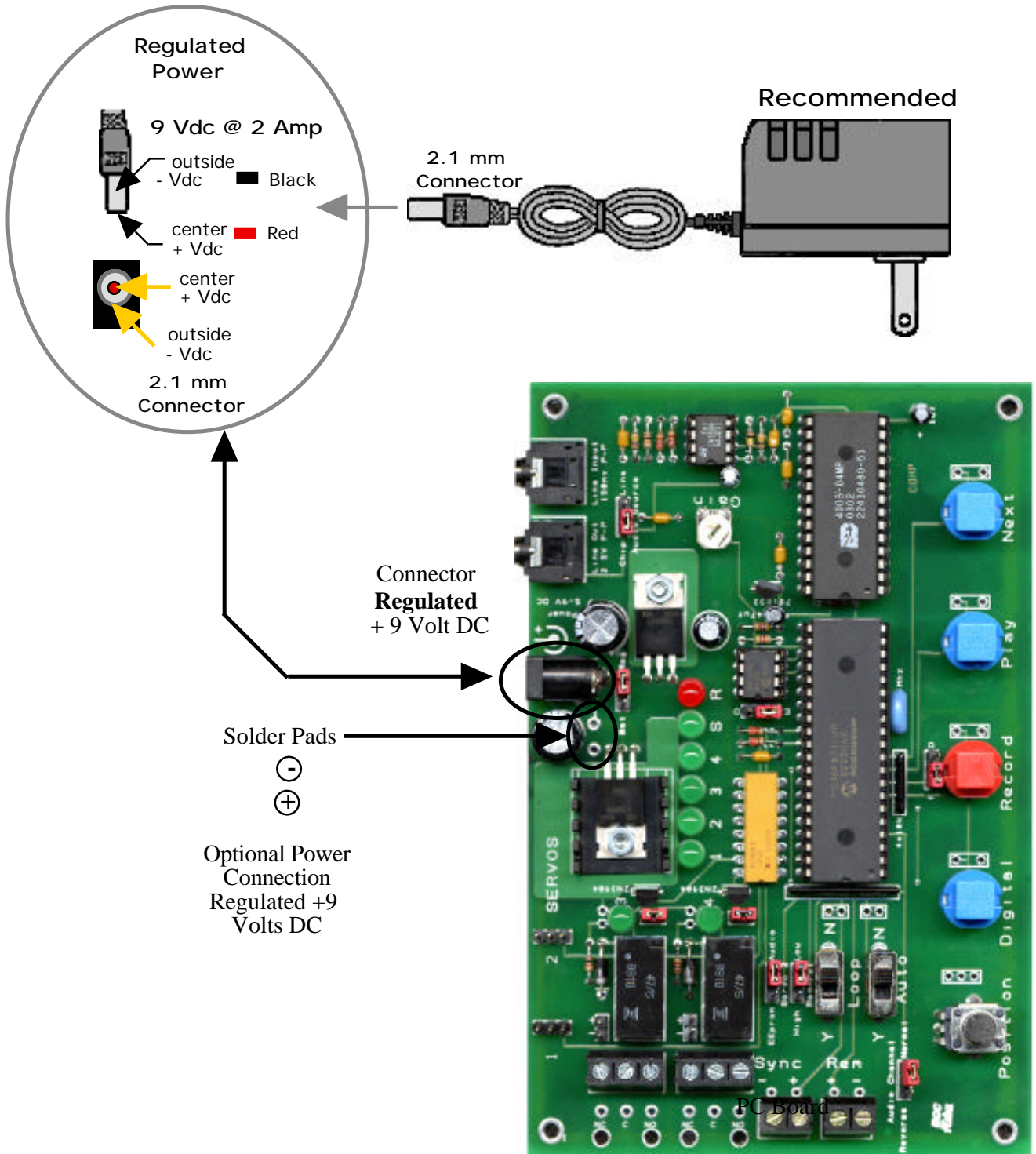

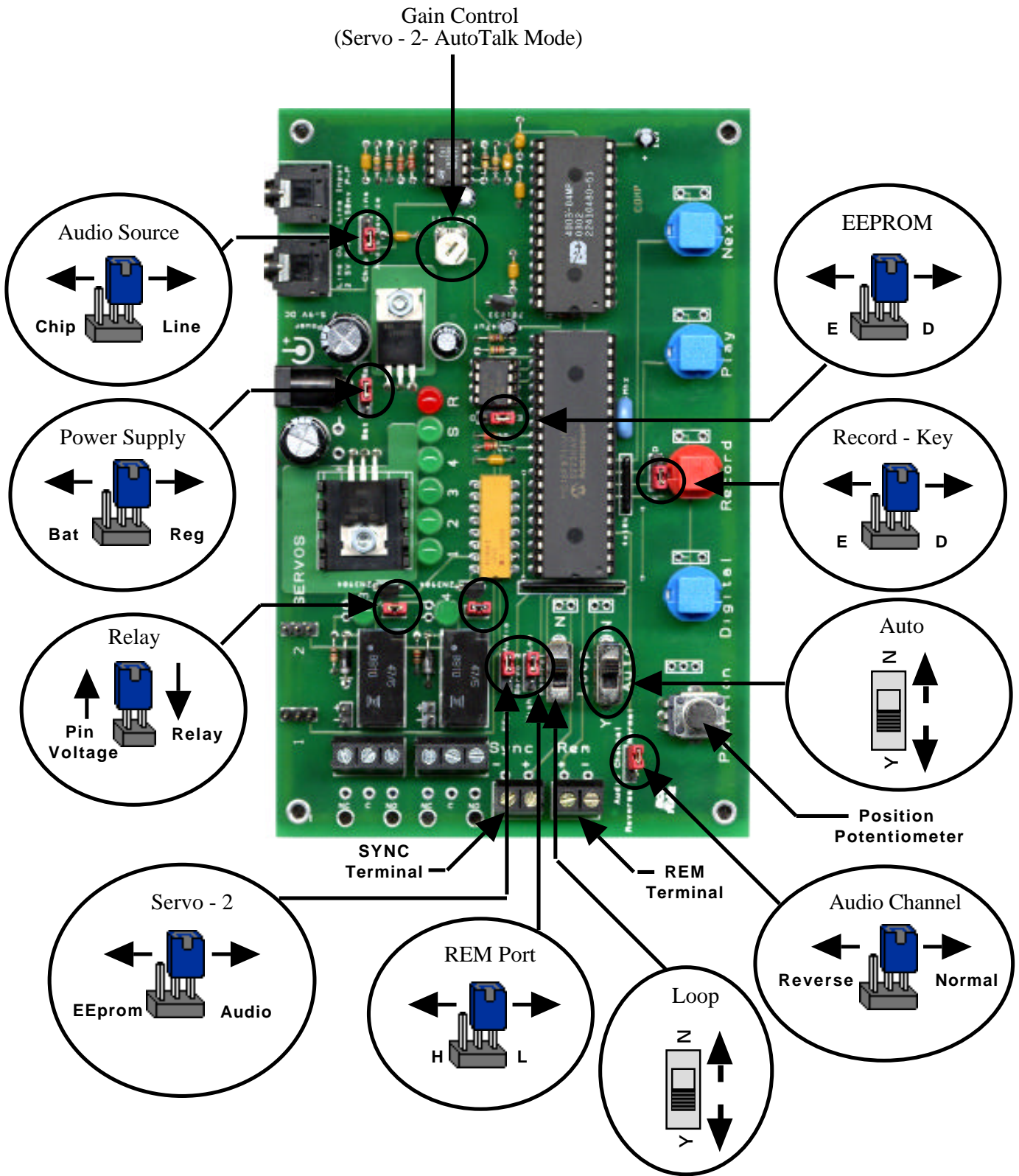

# Wizard -5 Controller Board Jumper Overview



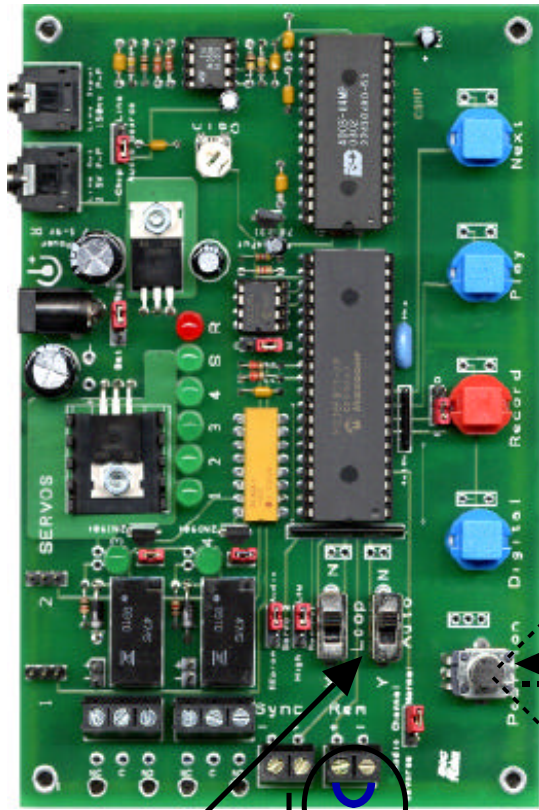

# Wizard - 5 Controller Board Remote Activation / Auto-Playback Playback Option Modes



- REMOTE SWITCH** 
- Floor Mat Switch.
  - PIR Sensor.
  - Manual Operated Switch.
  - Relay Contact Switch, etc.

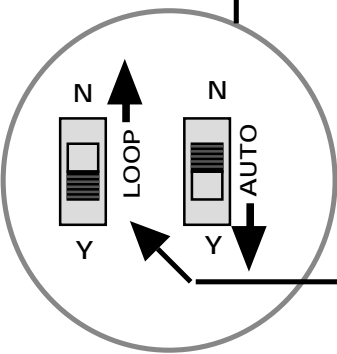
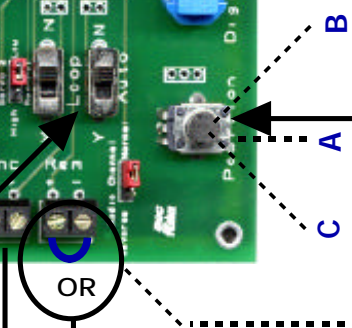
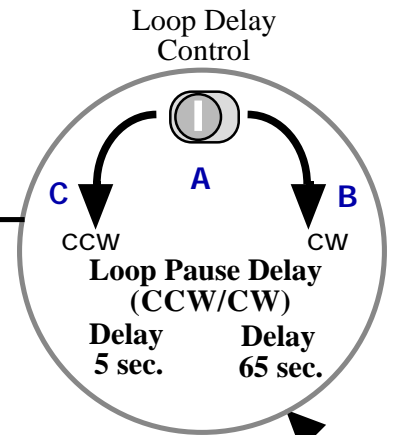

To replay the recorded action repeatedly, the LOOP selection switch must be in the "Y" position. The length of the pause between repeated playback is set by the Delay control, CCW (5 sec.) or CW (65 sec.).

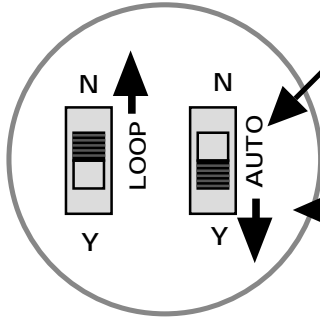

The PLAY key or REMOTE switch must be pressed once to start the playback action or if The AUTO selection switch is set to the "Y" position, then the recorded playback action will begin automatically each time on power-up.

Note: For a "0" pause delay between playback, set the LOOP selection switch to "N" and the AUTO selection switch to "Y". Place a jumper wire across the Remote Switch connection.

## Wizard - 5 Controller Board Multiple Board Connection



Example:  
Floor Mat Switch

**REMOTE SWITCH**

- Floor Mat Switch.
- PIR Sensor.
- Manual Operated Switch.
- Relay Contact Switch, etc.

Remote  
Switch / Sensor

Push Buttons  
(Momentary)



← Wizard 5 Board - Two      Wizard 5 Board - One

Wizard Board Three .....

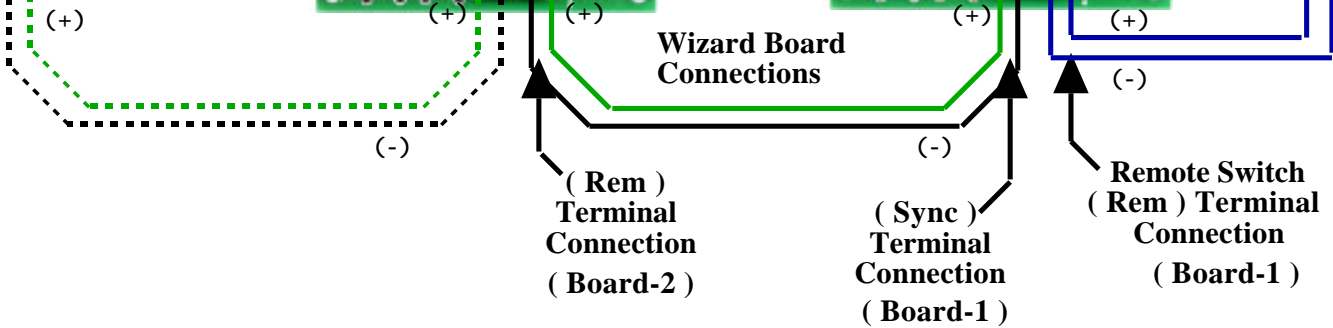
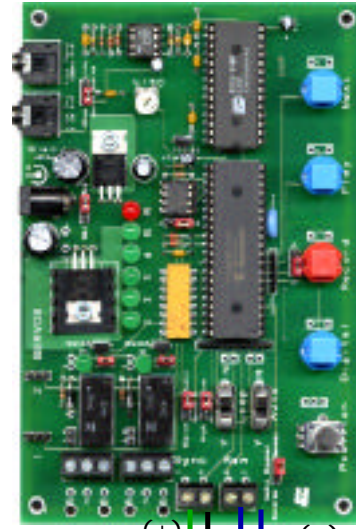
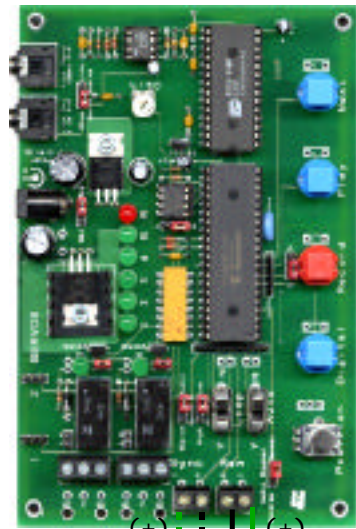

**The REMOTE switch on board One (Rem) when pressed will start board One (Sync) and Trigger board Two (Rem) and board Three ( Rem ) ..... etc, activating automatic program playback actions for all boards connected.**

# Wizard - 5 Controller Board Pneumatic Output Mode Electrical Pneumatic Valve

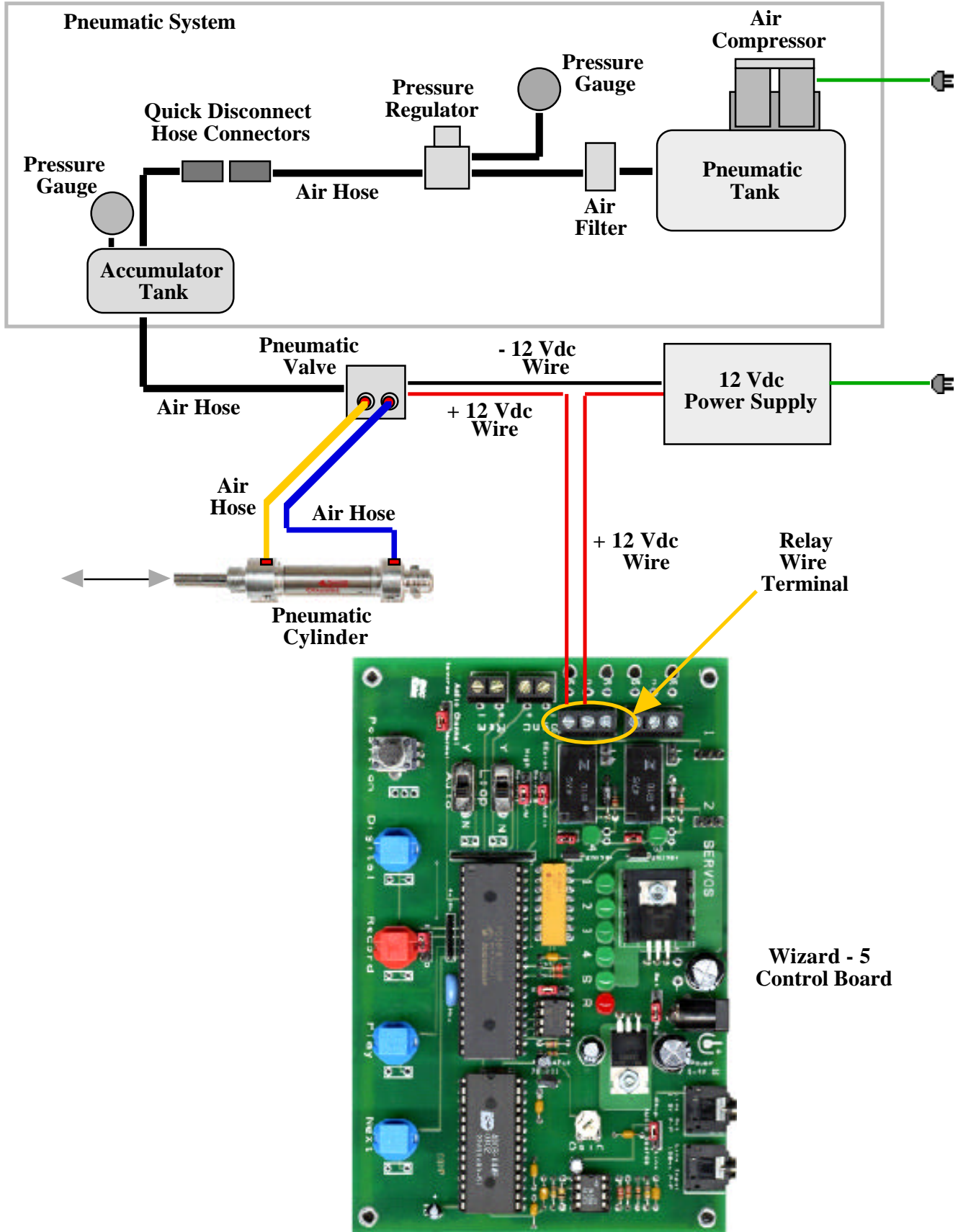

## Wizard - 5 Controller Board Relay to AC Voltage Output Mode

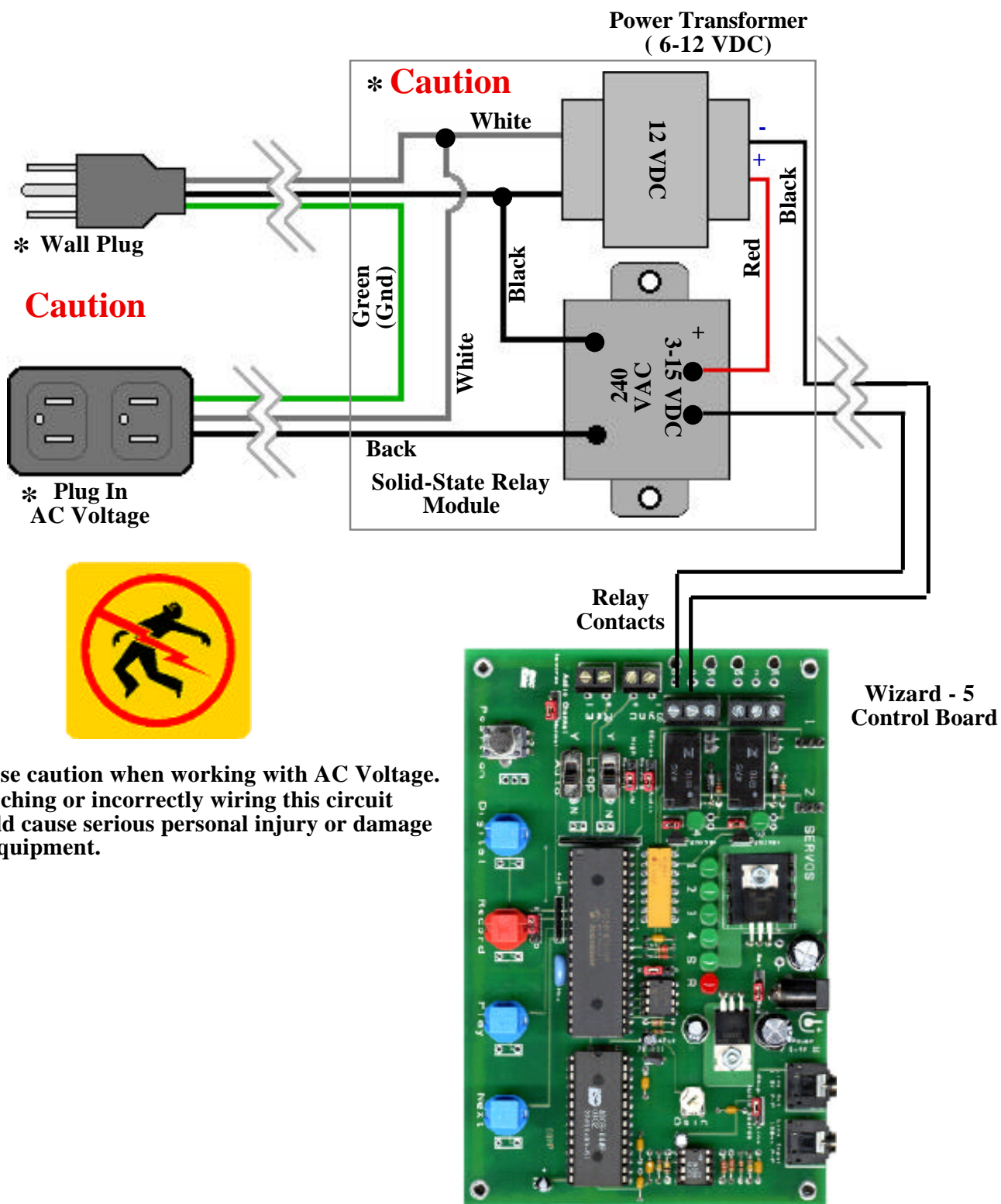

# Wizard - 5 Controller Board Servo Set-up Overview

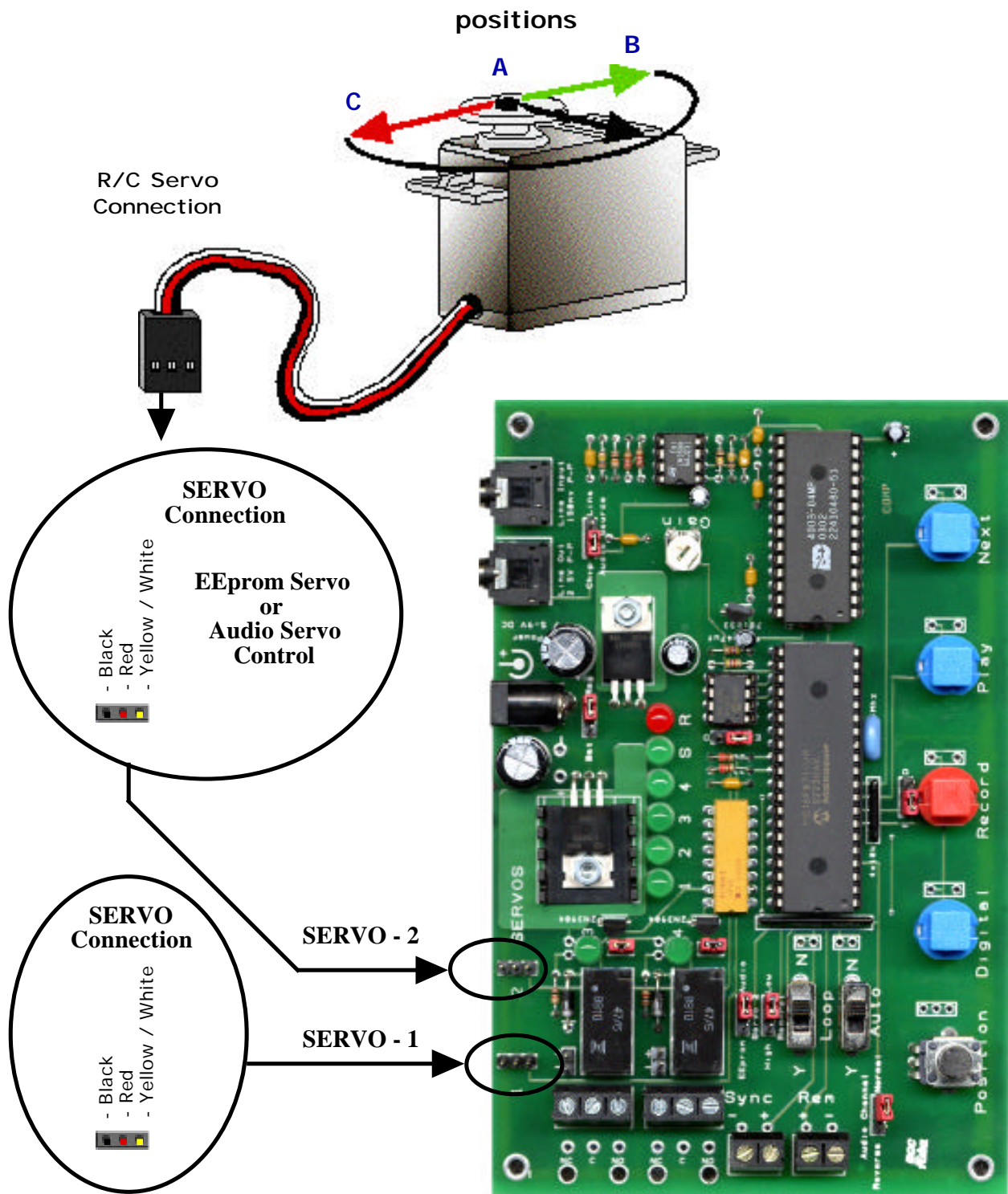

# Wizard - 5 Controller Board

## Audio Record / Playback Set-up Overview

**Sound Source Output**



**Sound Source**



**Computer Sound Port**



**CD Player**



**Mic Amp**



**Microphone**

**Audio Cable**

**Line Input**

**Sound INPUT**

**Line Out**

**Sound OUTPUT**

**Audio Cable**

**Speakers and Amplifier**

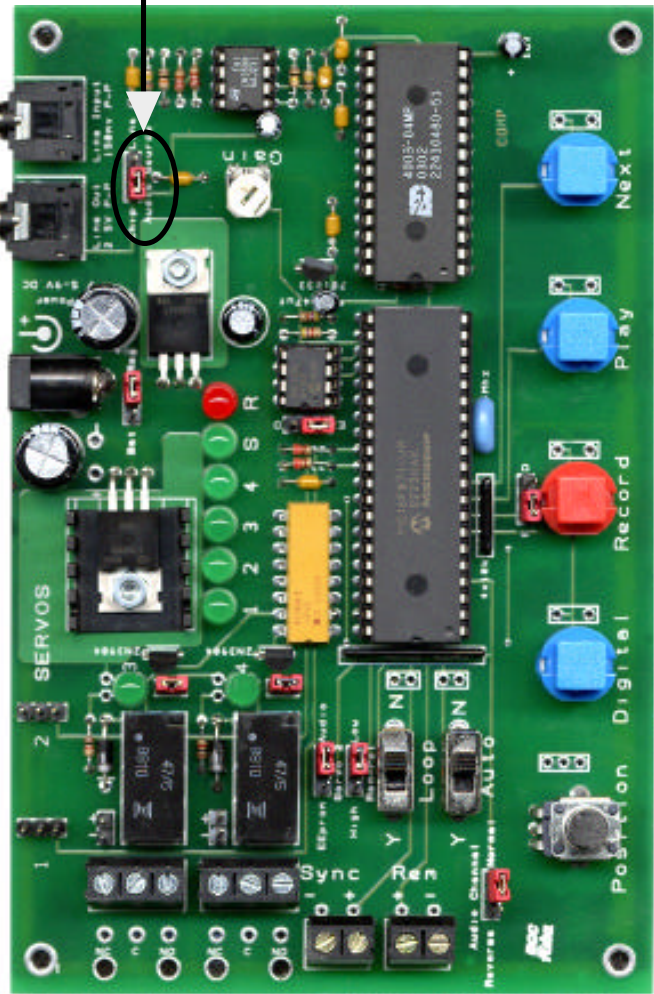
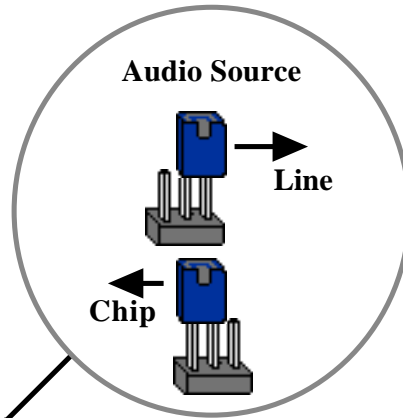
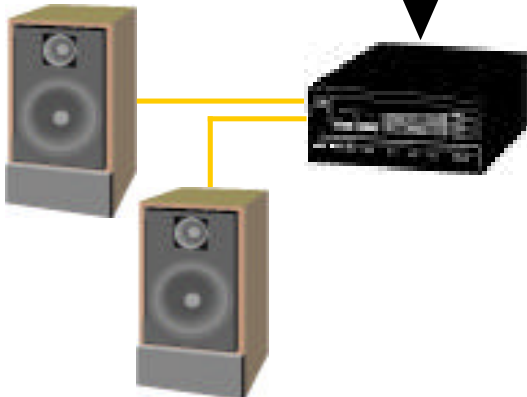

# Wizard - 5 Controller Board Sound / Servo - 2 Set-up Overview

