

DMX Ethernet



GENERAL INFORMATION

The Open DMX Ethernet (ODE) is a single port DMX to Ethernet node that can be configured as either an input or an output via Ethernet via a simple software utility. It is compatible with ESP and Art-Net DMX over Ethernet protocols.

APPLICATIONS

- OUTPUT for Ethernet enabled lighting consoles
- OUTPUT for PC-based lighting controllers
- INPUT for lighting visualizers
- INPUT for media servers
- INPUT AND OUTPUT (with 2 devices) to carry one of multiple universes of DMX data over Cat-5 wiring (or wirelessly)

FEATURES

- DMX -> Ethernet
- Ethernet-> DMX
- Tabletop or truss mountable
- 1 DMX input connector
- 1 DMX output connector (choose either input or output as connector for port.)
- 1 RJ45 Ethernet connection

- Regular model has external plug pack (voltage autoranging)
- POE version has Power Over Ethernet for single RJ45 cable connection
- Configured with free Node Management Utility (over Ethernet connection.)

ACCESSORIES

- Truss Mounting Yoke (not included)
- 3-pin to 5-pin Adapters (not included)
- Ethernet Hub (sold by others)
- POE Hub (sold by others)
- Wireless Ethernet Gateway (sold by others)

ACCESSORIES / SPARE PARTS

--	--

GENERAL SPECIFICATIONS

Power Requirements	90-260vac, 50-60Hz
Weight	.58 lbs / .26 kg
Shipped Weight	.68 lbs / .48 kg
Width:	5.12" / 130mm
Height	1.58" / 40mm
Depth	2.36" / 60mm
Operating Environment	0°-50°C in non-condensing environment

FUNCTIONAL SPECIFICATIONS

- DMX Input - 5 Pin XLR (use optional)
- DMX Output - 5 Pin XLR (will be passive throughput if input is active)
- 10/100BaseT Ethernet port
- Up to 256 DMX512 universes on a single Ethernet link
- Remote configuration using NMU to use any Art-Net or ESP universe (256 possible)
- User selectable IP Address and Device Name
- ENTTEC (ESP) and Art-Net protocol support

Open DMX Ethernet

Technical Illustration

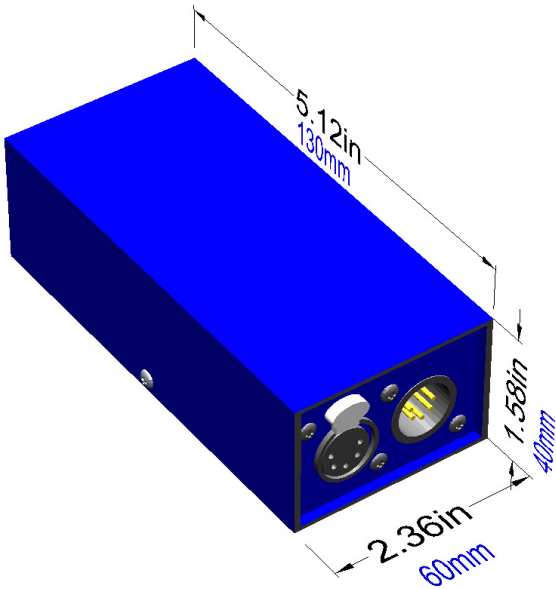

Wiring Diagrams (Riser)

